

brother

LT2-B841

2本針本縫針送りミシン

TWIN NEEDLE NEEDLE FEED LOCK STITCH MACHINE

DOPPELNADEL-VERRIEGELUNGSSTICHMASCHINE MIT NADELTRANSPORT

MACHINE A POINT NOUE A ENTRAINEMENT PAR AIGUILLE, A AIGUILLE JUMEELEE

MAQUINA DE COSER DOBLE PESPUNTEADORA, TRANSPORTE DE AGUJA Y DOS AGUJAS

パーツブック

PARTS BOOK

TEILEKATALOG

LIVRE DES PIECES

LIBRO DE REFERENCIA DE PIEZAS



P841101

LT2-B841

brother

Brother Sewing Machine Company
10000 W. Higgins Road
Brooklyn Park, MN 55420
USA

10000 W. Higgins Road
Brooklyn Park, MN 55420
USA

パーツブックご利用に際して

1. この本は、この本の表紙（正誤表の挿入されている場合は正誤表）に記載されているものと同じプレートが取り付けられているミシンのためのものです。
2. 組単位で補給する部品は、 破線で示しております。
3. 部品コード欄が*となっている場合は、仕様別部品一覧表（23ページ）でお調べ下さい。
5. この本は1991年1月のデータにもとづいて作成されたものです。
6. 部品は予告なしに設計変更される場合があります。

目 次

A. 主体関係	2
B. 上軸関係	2
C. 針棒揺動関係	4
D. 送り関係	4
E. 押エ関係	6
F. 送り軸関係	8
G. ゲージ部品	8
H. カマ関係	10
J. 下軸関係	12
K. 特別注文部品	12
L. 給油潤滑関係	14
M. 糸通シ関係	18
Z. 付属品関係	20
仕様別部品一覧表	23
ゲージ部品一覧表	24
索引	25～28

Notes for using this parts book

1. This book is applicable to sewing machine which have the same plate number as shown on the cover of this book (or correction sheet).
2. Parts supplied as complete assemblies are circled by a dotted line  .
3. If the symbol * is found in the "Parts No." column, refer to the different parts list on page 23.
4. This book was prepared based on information available in January 1991.
5. Parts are subject to changes in design without prior notice.

CONTENTS

A . Machine body	2
B . Upper shaft mechanism	2
C . Needle bar rocking mechanism	4
D . Feed mechanism	4
E . Presser foot mechanism	6
F . Feed shaft mechanism	8
G . Gauge parts	8
H . Rotary hook mechanism	10
J . Lower shaft mechanism	12
K . Option parts	12
L . Lubrication	14
M . Threading mechanism	18
Z . Accessories	20
GAUGE PARTS LIST	23
DIFFERENT PARTS LIST	24
INDEX	25-28

Hinweise Zur Verwendung dieser Teileise

1. Dieses Buch bezieht sich auf die Nähmaschinen mit derselben Kennungsnummer wie auf diesem Buchumschlag (oder auf dem Korrekturblatt).
2. Die Teile, die als kompletter Satz geliefert werden, sind mit einer  gestrichelten Linie umrandet.
3. Dieses Zeichen * in der Spalte "Parts No. (Teilnummer)" verweist auf die Gesonderte Stückliste auf Seite 23.
4. Dieses Buch basiert auf den Informationen vom Januar, 1991.
5. Modelländerungen sind vorbehalten.

INHALTSVERZEICHNIS

A . Maschinengehäuse	2
B . Obere Welle	2
C . Nadelstangenbetätigung	4
D . Transportvorrichtung	4
E . Stoffdrückerfuß	6
F . Transport welle	8
G . Lehren	8
H . Greifervorrichtung	10
J . Untere welle	12
K . Sonderzubehör	12
L . Schmierung	14
M . Fadenführungsvorrichtung	18
Z . Zubehör	20
LEHRENLISTE	23
ZUBEHÖRLISTE	24
VERZEICHNIS	25~28

Notes sur l'utilisation de ce manuel de pièces détachées



1. Ce manuel est destiné aux machines à coudre ayant le même numéro de plaque montré sur la couverture de ce manuel (ou sur la feuille de corrections).
2. Les pièces fournies en tant qu'assemblages complets sont encadrées avec un trait pointillé  .
3. Si le symbole * se trouve dans la colonne "Parts No. (N° de pièce)" veuillez la vous référer à la liste de pièces annexe page 23.
4. Ce manuel a été fait d'après les renseignements valables au mois de Janvier, 1991.
5. Les pièces peuvent être sujettes à des modifications sans préavis.

TABLE DES MATIERES

A .	Corps de la machine	2
B .	Mécanisme de l'arbre supérieur	2
C .	Mécanisme de balancement de la barre à aiguille	4
D .	Mécanisme de l'entraînement	4
E .	Mécanisme du pied presseur	6
F .	Mécanisme de l'arbre entraînement	8
G .	Pièces du gauge	8
H .	Mécanisme de crochet rotatif	10
J .	Mécanisme de l'arbre inférieur	12
K .	Pièces en option	12
L .	Lubrification	14
M .	Mécanisme de l'enfilage	18
Z .	Accessoires	20
	LISTE DE PIÈCES D'ECARTEMENT	23
	LISTE DES PIÈCES ACCESSOIRES	24
	INDEX	25-28

Notas para usar este Manual de Piezas

1. Este libro sirve para todas las máquinas de coser que llevan la misma placa de identificación que la que se puede ver en la tapa de este libro (o en la hoja de erratas).
2. Las piezas suministradas como conjuntos completos se enmarcan con una línea punteada  .
3. De haber un símbolo * junto al "Parts No. (Número de Pieza)", habrá que mirar la lista de piezas separada de la página 23.
4. Este libro ha sido compilado basándose en los datos de que se disponía en Enero, 1991.
5. Las piezas quedan sujetas a cambios de diseño sin aviso previo.

INDICE

A .	Cuerpo de la máquina	2
B .	Mecanismo de la eje superior	2
C .	Mecanismo de oscilación de la barra de aguja	4
D .	Mecanismo de la alimentación	4
E .	Mecanismo del prensa telas	6
F .	Mecanismo de la eje alimentación	8
G .	Piezas calibradoras	8
H .	Mecanismo del cangrejo	10
J .	Mecanismo de la eje inferior	12
K .	Piezas opciona	12
L .	Lubricación	14
M .	Mecanismo de la enhebrado	18
Z .	Accesorios	20
	LISTE DE PIEZAS CALIBRADORAS	23
	LISTA DE PIEZAS ACCESORIAS	24
	INDICE	25~28

A. 主体関係 / Machine body / Maschinengehäuse /
 Corps de la machine / Cuerpo de la máquina

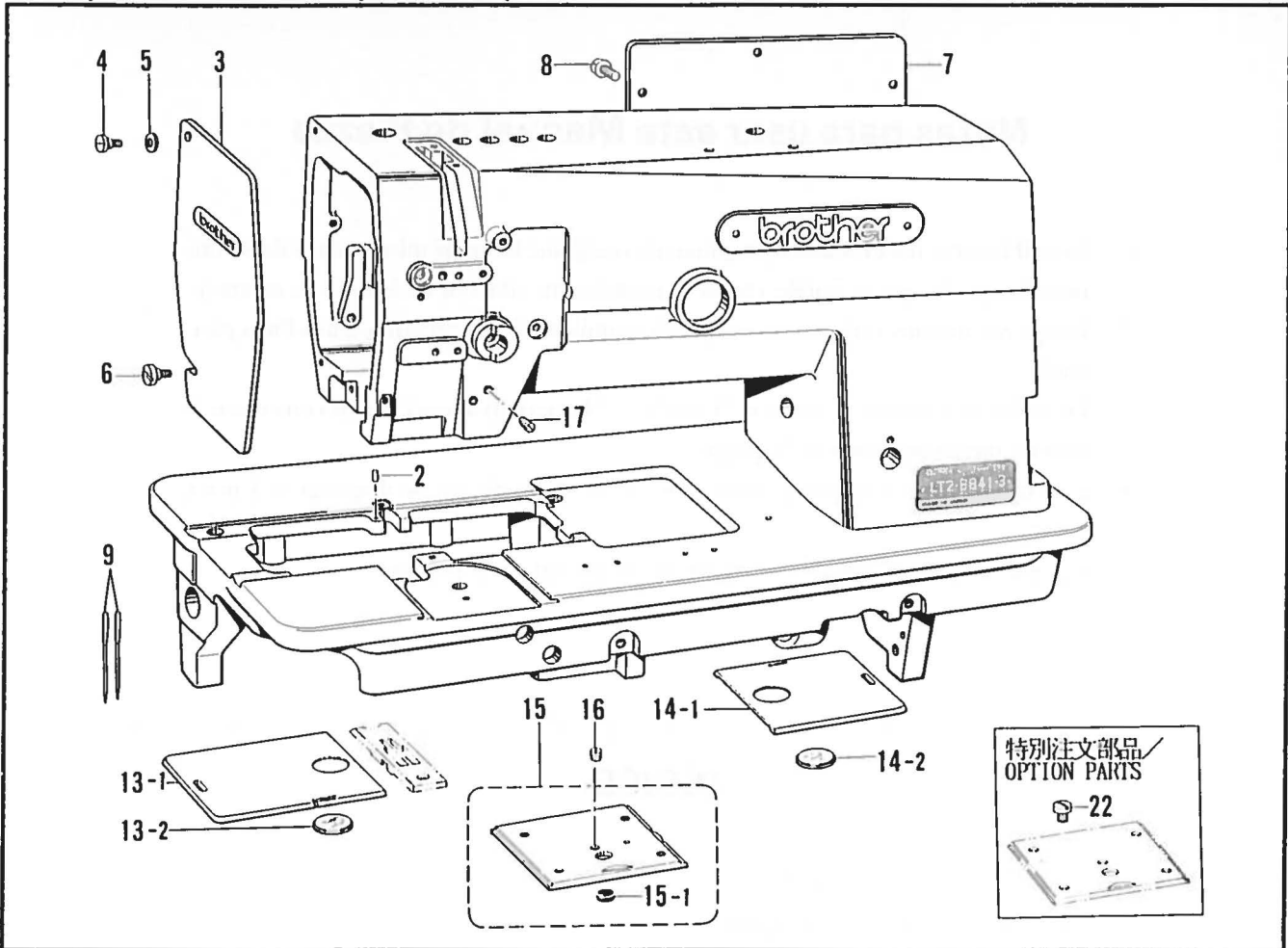

B. 上軸関係 / Upper shaft mechanism / Obere Welle /
 Mécanisme de l'arbre supérieur / Mecanismo de la eje superior

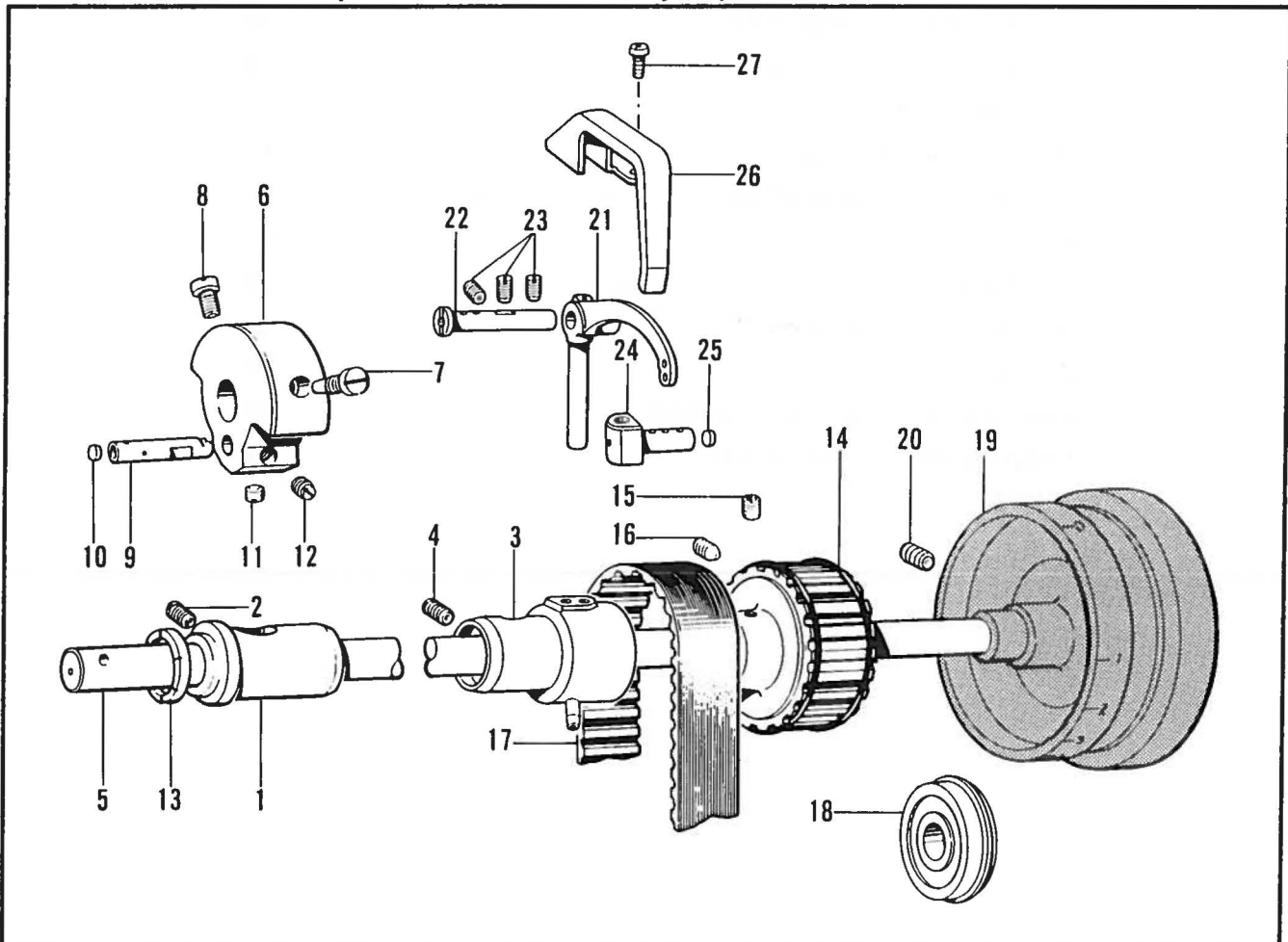

A. 主体関係/Machine body/Maschinengehäuse/
Corps de la machine/Cuerpo de la máquina

REF.NO.	CODE	Q'TY	ヒンメイ	NAME OF PARTS	RMKS
2	113386000	1	ハリタイチキメピン	POSITIONING PIN	
3	S07316009	1	メンイタ	FACE PLATE	
4	S07317001	1	タ"ンネシ"3.57	STUD SCREW 3.57	
5	146598001	1	ハ"ネサ"カ"ネ	SPRING WASHER	
6	129984002	1	ツマミネシ"3.57	SCREW 3.57	
7	S02499009	1	ガ"ワイタ	REAR COVER	
8	062680812	7	ナヘ"コ437-40X8	SCREW 437X8	
9	*	2	ミシンハリDPX5	NEEDLE DPX5	
13	*	1	スヘ"リイタLクミ	SLIDE PLATE (L) ASSEMBLY	
13-1	S07319101	1	スヘ"リイタL	SLIDE PLATE (L)	
13-2	S07320000	1	スヘ"リイタマト"	BOBBIN WINDOW	
14	S07325201	1	スヘ"リイタRクミ	SLIDE PLATE (R) ASSEMBLY	
14-1	S07326101	1	スヘ"リイタR	SLIDE PLATE (R)	
14-2	S07320000	1	スヘ"リイタマト"	BOBBIN WINDOW	
15	112610101	1	スヘ"リイタFクミ	SLIDE PLATE (F) ASSEMBLY	
15-1	S07328000	1	ゴムセン	OIL CAP	
16	116010001	1	トメネシ"5.16	SET SCREW 5.16	
17	151602002	2	トメネシ"4.37	SET SCREW 4.37	
<トクベツチュウモンブピン/OPTION PARTS >					
22	113760001	4	シメネシ"5.16	SCREW 5.16	

◎ ※印の付いている部品の部品コードをお調べの場合は、P24のゲージ部品一覧表をご覧ください。
 ◎ If there is a "※" mark, refer to the gauge assembly guide on page 24.
 ◎ Falls das Zeichen "※" steht, wird auf die Zusammenstellung der Vorrichtungen auf Seite 24 verwiesen.
 ◎ Si le signe "※" apparaît, se reporter à la page 24 du guide de montage de la jauge.
 ◎ Si aparece una marca "※", consultar la guía de armado de galga en la página 24.

B. 上軸関係/Upper shaft mechanism/Obere Welle/
Mécánisme de l'arbre supérieur/Mecanismo de la eje superior

REF.NO.	CODE	Q'TY	ヒンメイ	NAME OF PARTS	RMKS
1	112573101	1	ウフジ"クメタルL	UPPER SHAFT BUSH (L)	
2	013781012	1	トメネシ"6.35クホ"ミ	SET SCREW 6.35	
3	S07330101	1	ウフジ"クメタルMクミ	UPPER SHAFT BUSH (M) ASSEMBLY	
4	013780710	1	トメネシ"6.35クホ"ミ	SET SCREW 6.35	
5	S07329001	1	ウフジ"ク	UPPER SHAFT	
6	112574000	1	テンヒ"ンクランク	THREAD TAKE-UP CRANK	
7	100250001	1	シメネシ"7.14	SCREW 7.14	
8	146141001	1	アタマツキトメネシ"7.14	SET SCREW 7.14	
9	112577101	1	ハリホ"ウクランク	NEEDLE BAR CRANK	
10	113014000	1	クミヒモフタ	PUSHER	
11	101706001	1	トメネシ"6.35	SET SCREW 6.35	
12	100251001	1	トメネシ"6.35	SET SCREW 6.35	
13	112576001	1	テンヒ"ンクランクリング"	THREAD TAKE-UP CRANK RING	
14	180157001	1	タイミング"プー"リUクミ	TIMING PULLEY (U) ASSEMBLY	
15	014771022	1	アトメネシ"6.35クホ"ミ	SET SCREW 6.35	
16	016771032	1	アトカ"リ635X10	SET SCREW 635X10	
17	112586001	1	タイミング"ヘル"ト	TIMING BELT	
18	158115001	1	タマシ"クウク6204ZZNR	BALL BEARING 6204ZZNR	
19	142112009	1	プー"リ	PULLEY	
20	S09670001	2	トメクホ"ミ595-28X14	SET SCREW 595X14	
21	*	1	テンヒ"ン	THREAD TAKE-UP	
22	S07334001	1	テンヒ"ンシ"ク	THREAD TAKE-UP SHAFT	
23	013781012	3	トメネシ"6.35クホ"ミ	SET SCREW 6.35	
24	S07338001	1	テンヒ"ンスヘ"リコ	THREAD TAKE-UP SLIDE BLOCK	
25	113024000	1	クミヒモフタ	PUSHER	
26	S07339009	1	テンヒ"ンカバー	THREAD TAKE-UP COVER	
27	062670512	2	ナヘ"コ357-40X5	SCREW 357X5	

C. 針棒揺動関係/Needle bar rocking mechanism/Nadelstangenbetätigung/
 Mécanisme de balancement de la barre à aiguille/Mecanismo de oscilación de la barra de aguja

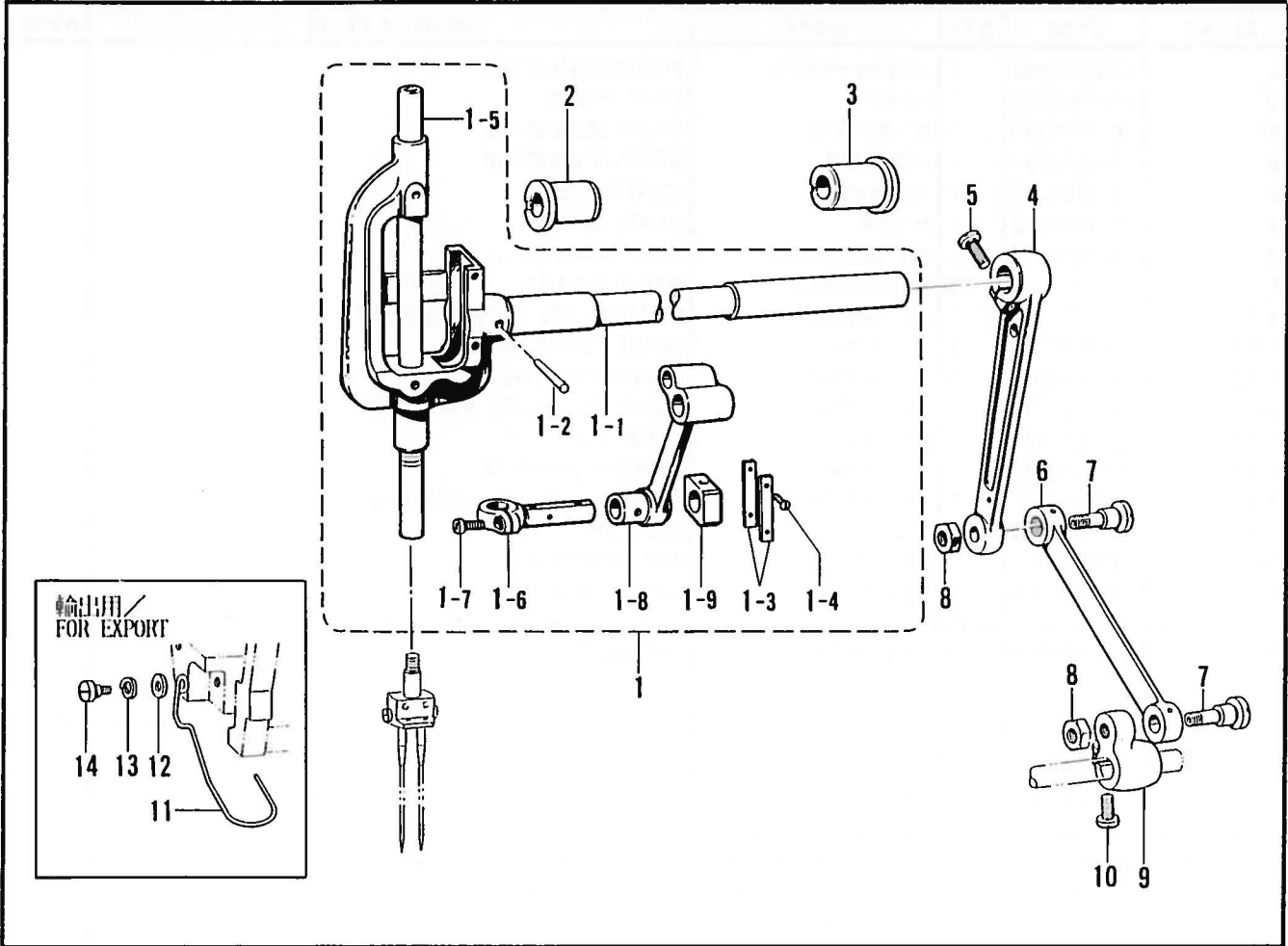

D. 送り関係/Feed mechanism/Transportvorrichtung/
 Mécanisme de l'entraînement/Mecanismo de la alimentación

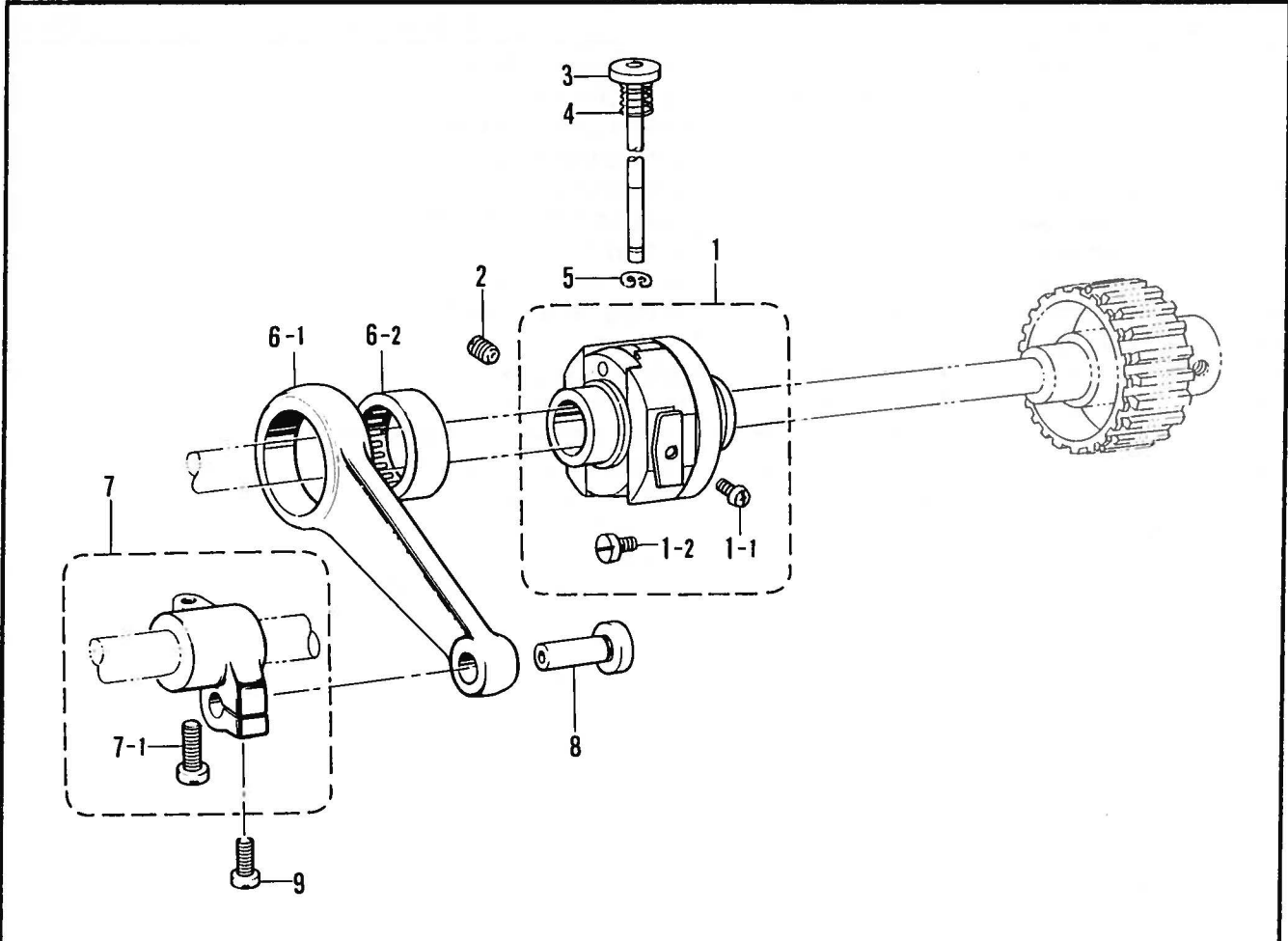

C. 針棒揺動関係/Needle bar rocking mechanism/Nadelstangenbetätigung/
 Mécanisme de balancement de la barre à aiguille/Mecanismo de oscilación de la barra de aguja

REF.NO.	CODE	Q'TY	ヒンメイ	NAME OF PARTS	RMKS
1	159359201	1	ハリホ"ウヨウト"ウジ"ククミ	NEEDLE BAR ROCK SHAFT ASSEMBLY	
1-1	112588101	1	ハリホ"ウヨウト"ウジ"ク	NEEDLE BAR ROCK SHAFT	
1-3	112590001	2	ハリホ"ウアンナイイタ	GUIDE PLATE	
1-4	102731004	4	サラネジ"2.38	SCREW 2.38	
1-5	159360101	1	ハリホ"ウ	NEEDLE BAR	
1-6	112592001	1	ハリホ"ウタ"キ	NEEDLE BAR CLAMP	
1-7	062670812	1	ナヘ"コ357-40X8	SCREW 357X8	
1-8	112593001	1	ハリホ"ウ克蘭クロット"	NEEDLE BAR CRANK ROD	
1-9	112721001	1	ハリホ"ウレンカンカクコマ	SLIDE BLOCK	
2	112594001	1	ヨウト"ウジ"クメタルL	NEEDLE BAR ROCK SHAFT BUSH (L)	
3	112764001	1	ヨウト"ウジ"クメタルR	NEEDLE BAR ROCK SHAFT BUSH (R)	
4	112595000	1	ハリホ"ウヨウト"ウレンカン	NEEDLE BAR ROCK CONNECTING ROD	
5	105351002	1	シメネジ"6.35	SCREW 6.35	
6	112596001	1	ハリホ"ウヨウト"ウリンク	NEEDLE BAR ROCK LINK	
7	112597001	2	ヨウト"ウリンク"ウジ"ク	NEEDLE BAR ROCK LINK STUD	
8	101268002	2	ナツト7.94	NUT 7.94	
9	112598001	1	ハリホ"ウヨウト"ウ克蘭ク	NEEDLE BAR CONNECTING CRANK	
10	S01304001	1	シメネジ"6.35X18	SCREW 6.35X18	
11	S07344101	1	-----	FINGER GUARD	
12	146354001	1	-----	WASHER	
13	028680242	1	-----	SPRING WASHER 2-4.37	
14	117850001	1	-----	STUD SCREW 3.57	

D. 送り関係/Feed mechanism/Transportvorrichtung/
 Mécanisme de l'entraînement/Mecanismo de la alimentación

REF.NO.	CODE	Q'TY	ヒンメイ	NAME OF PARTS	RMKS
1	112673001	1	ヘンシンリンクミ	ECCENTRIC WHEEL ASSEMBLY	
1-1	062660412	1	ナヘ"コ318-40X4	SCREW 318X4	
1-2	101479001	2	シメネジ"3.18	NEEDLE PLATE RULER SET SCREW 3.18	
2	013761410	2	トメネジ"5.95クホ"ミ	SET SCREW 5.95	
3	S07360001	1	オクリチヨウセツホ"タン	LENGTH CONTROL BUTTON	
4	118718001	1	オサエホ"ウタ"キオシハ"ネ	SPRING	
5	048040342	1	トメワE4	STOP RING E4	
6	115262001	1	スイハイオクリレンカンクミ	LEVEL FEED CONNECTING ROD ASSEMBLY	
6-1	112678000	1	スイハイオクリレンカン	LEVEL FEED CONNECTING ROD	
6-2	118954000	1	ニート"ルハ"アリング"	NEEDLE BEARING	
7	180733001	1	スイハイオクリウテ"ネジ"ツキ	FEED ROCK SHAFT ARM WITH SCREW	
7-1	S01304001	1	シメネジ"6.35X18	SCREW 6.35X18	
8	112681001	1	スイハイオクリウテ"シ"ク	HORIZONTAL FEED ARM STUD	
9	062681212	1	ナヘ"コ437-40X12	SCREW 437X12	

E. 押工関係/Presser foot mechanism/Stoffdrückerfuß/
Mécanisme du pied presseur/Mecanismo del prensa telas

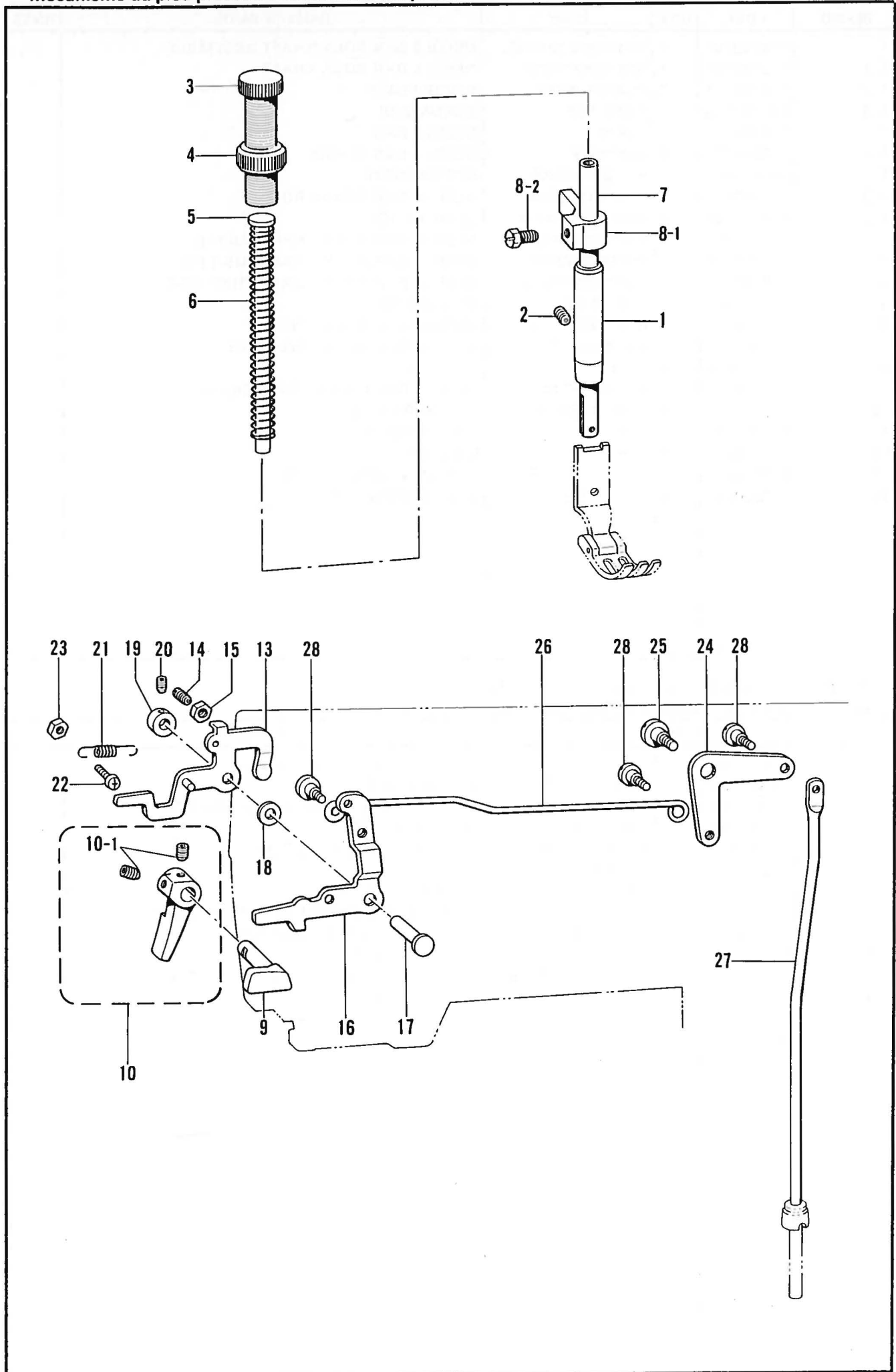

E. 押工関係/Presser foot mechanism/Stoffdrückerfuß/
Mécanisme du pied presseur/Mecanismo del prensa telas

REF.NO.	CODE	Q'TY	ヒンメイ	NAME OF PARTS	RMKS
1	145472001	1	オサエホ"ウメタル	PRESSER BAR BUSH	
2	013781012	1	トメネシ"6.35クホ"ミ	SET SCREW 6.35	
3	141207001	1	オサエチヨウセツネシ"	ADJUST SCREW	
4	147846002	1	チヨウセツネシ"ツマミナツト	NUT	
5	141208001	1	オサエハ"ネアンナイ	SPRING GUIDE	
6	S07346101	1	オサエハ"ネ	SPRING	
7	S07345001	1	オサエホ"ウ	PRESSER BAR	
8	181919101	1	オサエホ"ウダ"キネシ"ツキ	PRESSER BAR CLAMP WITH SCREW	
8-1	147513001	1	オサエホ"ウダ"キ	PRESSER BAR GUIDE CLAMP	
8-2	142403001	1	ホ"ルトツ5.95	BOLT 5.95	
9	S07347001	1	オサエアケ"クランク	PRESSER BAR LIFTER CRANK	
10	S13103009	1	オサエアケ"テコネシ"ツキ	PRESSER BAR LIFTER WITH SCREW	
10-1	014710522	2	アトメネシ"4.76クホ"ミ	SET SCREW 4.76	
13	S07353001	1	イトユルメイタクミ	TENSION RELEASE PLATE ASSEMBLY	
14	S07356001	1	トメネシ"6.35ヒラ	SET SCREW 6.35	
15	150556001	1	ナツト6.35	NUT 6.35	
16	S07348001	1	オサエアケ"レハ"ー	PRESSER BAR LIFTER LEVER	
17	S07349001	1	オサエアケ"レハ"ー"ジ"ク	PRESSER BAR LIFTER LEVER STUD	
18	S07350001	1	サ"ガ"ネ	WASHER	
19	139096001	1	セツトカラ"ー	SET COLLAR	
20	014680422	2	アトメネシ"4.37クホ"ミ	SET SCREW 4.37	
21	S07355001	1	オサエアケ"レハ"ー"ハ"ネ	SPRING	
22	062671412	1	ナヘ"コ357-40X14	SCREW 357X14	
23	021670102	1	ナツト1シユ3.57	NUT 3.57	
24	S07358001	1	ヒサ"アケ"レハ"ー	KNEE LIFTER LEVER	
25	145480001	1	タ"ンネシ"6.35	STUD SCREW 6.35	
26	S07357001	1	ヒサ"アケ"レンカン	KNEE LIFTER CONNECTING ROD	
27	S07359001	1	ヒサ"アケ"ホ"ウ	KNEE LIFTER BAR	
28	145478001	3	タ"ンネシ"4.76	STUD SCREW 4.76	

F. 送り軸関係/Feed shaft mechanism/Transport welle/
 Mécanisme de l'arbre entraînement/Mecanismo de la eje alimentación

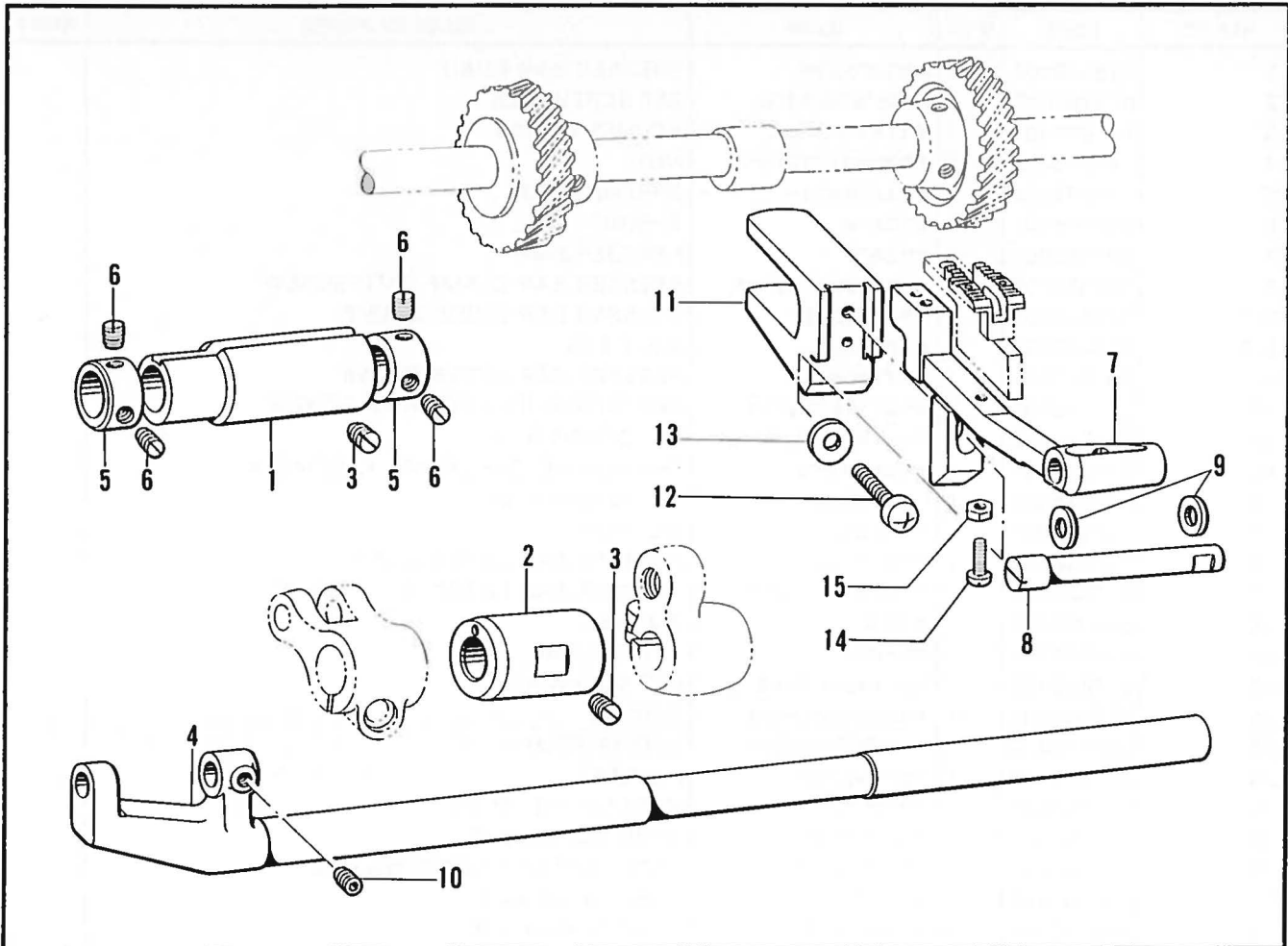

G. ゲージ部品/Gauge parts/Lehren/
 Pièces du gauge/Piezas calibradoras

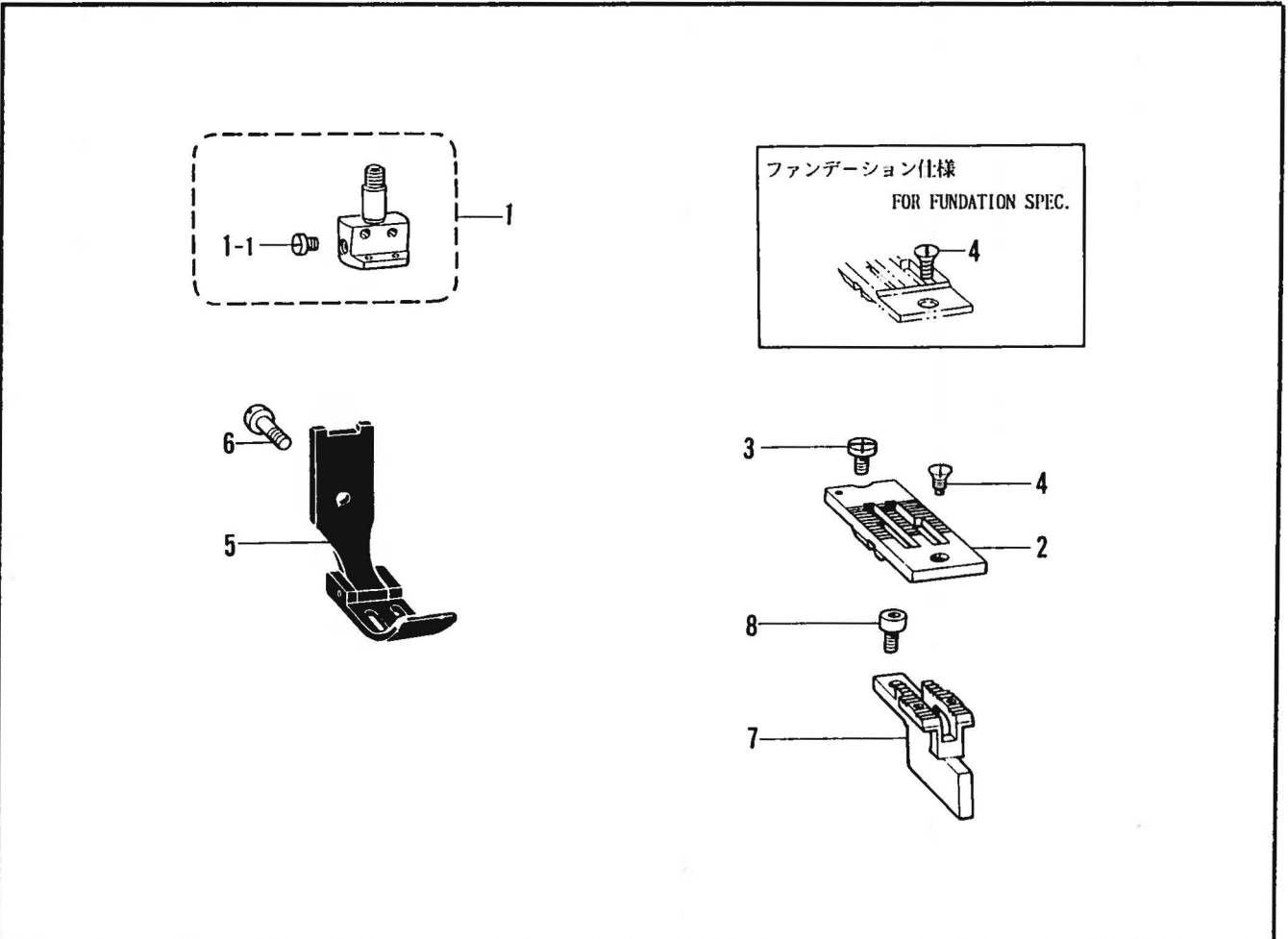

F. 送り軸関係/Feed shaft mechanism/Transport welle/
Mécanisme de l'arbre entrainement/Mecanismo de la eje alimentación

REF.NO.	CODE	Q'TY	ヒンメイ	NAME OF PARTS	RMKS
1	148494001	1	オクリシ"クメタルL	FEED SHAFT BUSH (L)	
2	S07386001	1	オクリシ"クメタルR	FEED SHAFT BUSH (R)	
3	013781012	2	トメネシ"6.35クホ"ミ	SET SCREW 6.35	
4	148492101	1	スイヘイオクリシ"ク	FEED ROCK SHAFT	
5	113074001	2	セツトカラー	SET COLLAR	
6	101706001	4	トメネシ"6.35	SET SCREW 6.35	
7	S07387001	1	オクリタ"イ	FEED BAR	
8	148491001	1	オクリタ"イトリツケシ"ク	FEED BAR SHAFT	
9	143591001	2	スラストリング"	THRUST RING	
10	014680622	1	アナトメネシ"4.37クホ"ミ	SET SCREW 4.37	
11	112656001	1	オクリタ"イフタマタ	FEED BAR FORK	
12	062761412	1	ナヘ"コ595-28X14	SCREW 595X14	
13	025060132	1	ヒラサ"ガ"ネシヨウ6	PLAIN WASHER 6	
14	062661212	1	ナヘ"コ318-40X12	SCREW 318X12	
15	021660102	1	ナツト1 シユ3.18	NUT 3.18	

G. ゲージ部品/Gauge parts/Lehren/
Pièces du gauge/Piezas calibradoras

REF.NO.	CODE	Q'TY	ヒンメイ	NAME OF PARTS	RMKS
1	※	1	ハリタ"キクミ	NEEDLE CLAMP ASSEMBLY	
1-1	116323001	2	シメネシ"3.57	SCREW 3.57	
2	※	1	ハリイタ	NEEDLE PLATE	
3	S11244001	1	シメネシ"4.37	SCREW 4.37	
4	*	1	サラネシ"4.37	SCREW 4.37	
5	※	1	オサエクミ	PRESSER FOOT ASSEMBLY	
6	113050001	1	シメネシ"3.57	SCREW 3.57	
7	※	1	オクリハ"	FEED DOG	
8	S07494001	2	シメネシ"3.18	SCREW 3.18	

◎ ※印の付いている部品の部品コードをお調べの場合は、P24のゲージ部品一覧表をご覧ください。
◎ If there is a "※" mark, refer to the gauge assembly guide on page 24.
◎ Falls das Zeichen "※" steht, wird auf die Zusammenstellung der Vorrichtungen auf Seite 24 verwiesen.
◎ Si le signe "※" apparaît, se reporter à la page 24 du guide de montage de la jauge.
◎ Si aparece una marca "※", consultar la guía de armado de galga en la página 24.

H. カマ関係 / Rotary hook mechanism / Greifervorrichtung / Mécanisme de crochet rotatif / Mecanismo del cangrejo

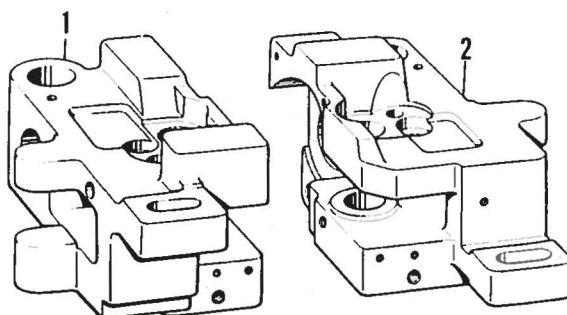
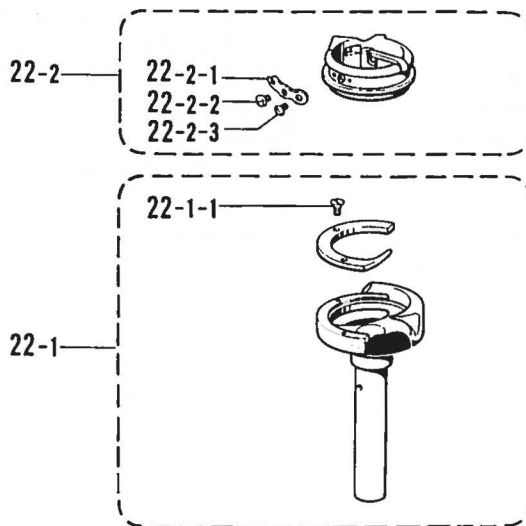
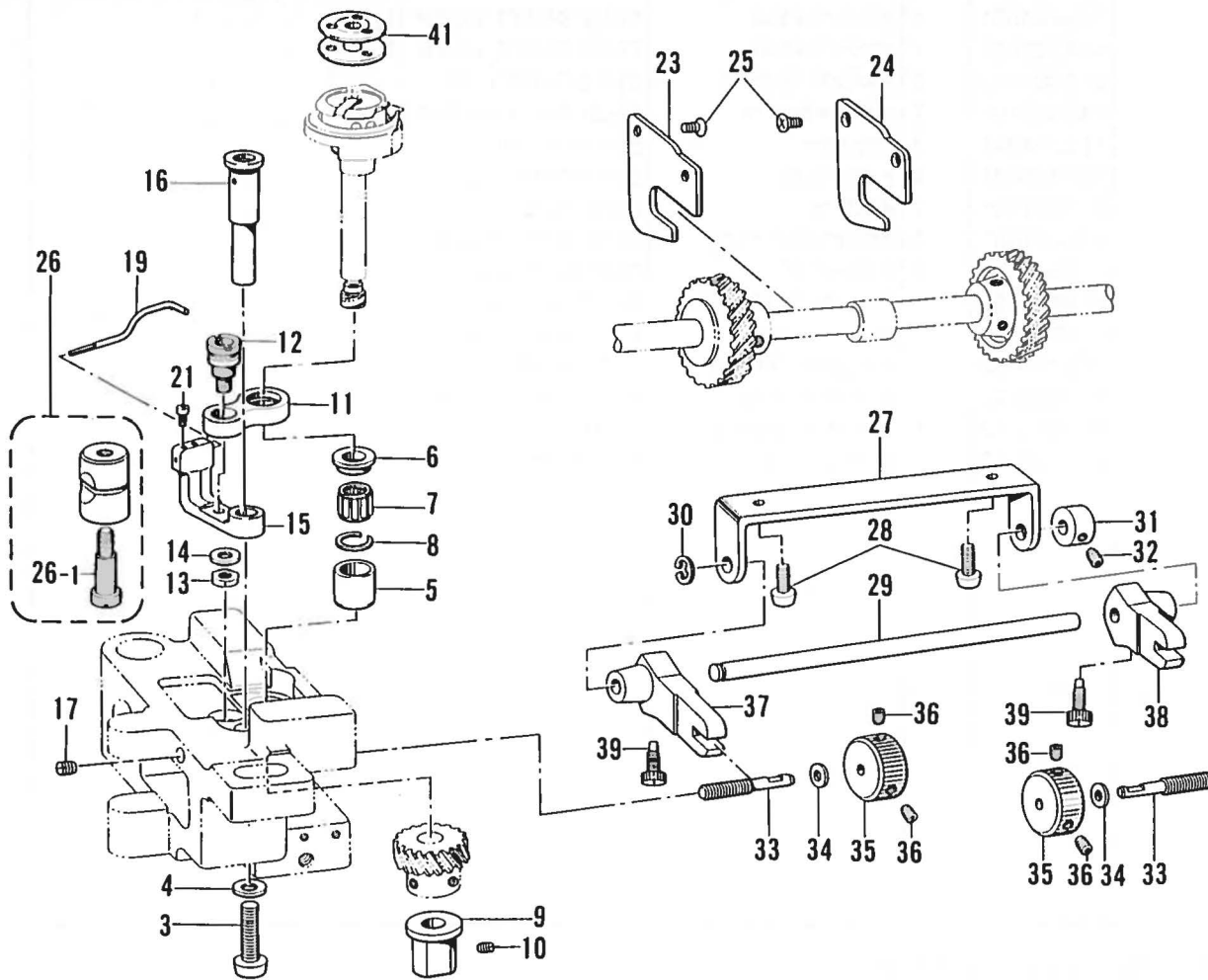

H. カマ関係/Rotary hook mechanism/Greifervorrichtung/
Mécánisme de crochet rotatif/Mecanismo del cangrejo

REF.NO	CODE	Q'TY	ヒンメイ	NAME OF PARTS	RMKS
1	S07416201	1	カマト"ダ"イル	ROTARY HOOK BASE (L)	
2	S07414201	1	カマト"ダ"イルR	ROTARY HOOK BASE (L)	
3	062782512	2	ナヘ"コ635-28X25	SCREW 635X25	
4	100197002	2	サ"カ"ネ	WASHER	
5	S07418001	2	カマジ"クメタルU	ROTARY HOOK SHAFT BUSH (U)	
6	S07421001	2	スラストリング"	THRUST RING	
7	S07420000	2	ニードル"ル"へ"アリング"	NEEDLE BEARING	
8	S07419001	2	ストップ"リング"	STOP RING	
9	S07417001	2	カマジ"クメタルD	ROTARY HOOK SHAFT BUSH (D)	
10	013710512	2	トメネジ"4.76クボ"ミ	SET SCREW 4.76	
11	112692101	2	オープ"ナー"リンク	OPENER LINK	
12	148005001	2	オープ"ナー"リンクシ"ク	OPENER LINK SHAFT	
13	110161006	2	ナツト4.76	NUT 4.76	
14	025710232	2	ヒラサ"カ"ネチユウ4.76	PLAIN WASHER 4.76	
15	S07422101	2	オープ"ナー"レバ"ー	OPENER LEVER	
16	S13021001	2	オープ"ナー"レバ"ー"シ"ク	OPENER LEVER SHAFT	
17	013711012	2	トメネジ"4.76クボ"ミ	SET SCREW 4.76	
19	S07423101	2	オープ"ナー	OPENER	
21	S07424001	4	トメネジ"3.18	SET SCREW 3.18	
23	S07436001	1	キ"ヤアン"ナイL	GEAR GUIDE (L)	
24	S07437001	1	キ"ヤアン"ナイR	GEAR GUIDE (R)	
25	108960002	4	サラネジ"3.57	SCREW 3.57	
26	S07658001	2	ピンチスリーブ"ク"ミ	PINCH SLEEVE ASSEMBLY	
26-1	112700001	2	シメネジ"5.95	SCREW 5.95	
27	S07430001	1	ハリスキチヨウセツホ"ウササエ	ADJUST BAR SUPPORT	
28	062711012	2	ナヘ"コ476-32X10	SCREW 476X10	
29	S07431001	1	ハリスキチヨウセツホ"ウ	ADJUST BAR	
30	048040342	1	トメフE4	STOP RING E4	
31	159436001	1	セツトカラー	SET COLLAR	
32	014680622	1	アナトメネジ"4.37クボ"ミ	SET SCREW 4.37	
33	S07434001	2	ハリスキチヨウセツネジ"	ADJUST SCREW	
34	025680132	2	ヒラサ"カ"ネシヨウ4.37	PLAIN WASHER 4.37	
35	S07435001	2	ハリスキチヨウセツナツト	ROTARY HOOK BASE ADJUST DIAL	
36	014680622	4	アナトメネジ"4.37クボ"ミ	SET SCREW 4.37	
37	S07432001	1	ハリスキチヨウセツフタマタL	ADJUST FORKED LEVER (L)	
38	S07433001	1	ハリスキチヨウセツフタマタR	ADJUST FORKED LEVER (R)	
39	131226001	2	ハリトメネジ"3.57	NEEDLE SET SCREW 3.57	
40	112781101	2	ホ"ビ"ン	BOBBIN	
< -1, -3 >					
22	S07425001	2	ニホンハリカマ	ROTARY HOOK ASSEMBLY	
22-1	S07731001	2	ソトカマクミ	OUTER ROTARY HOOK ASSEMBLY	
22-1-1	151027001	4	ウチカマオサエトメネジ"	INNER ROTARY HOOK SET SCREW	
22-2	S07735001	2	ウチカマクミ	INNER ROTARY HOOK ASSEMBLY	
22-2-1	151145001	2	チヨウシハ"ネ	TENSION SPRING	
22-2-2	151029001	2	チヨウシネジ"	TENSION ADJUST SCREW	
22-2-3	151030001	2	チヨウシハ"ネトメネジ"	SET SCREW	
< -5 >					
22	S07426001	2	ニホンハリカマ	ROTARY HOOK ASSEMBLY	
22-1	S07732001	2	ソトカマクミ	OUTER ROTARY HOOK ASSEMBLY	
22-1-1	151027001	4	ウチカマオサエトメネジ"	INNER ROTARY HOOK SET SCREW	
22-2	S07736001	2	ウチカマクミ	INNER ROTARY HOOK ASSEMBLY	
22-2-1	151146001	2	チヨウシハ"ネ	TENSION SPRING	
22-2-2	151029001	2	チヨウシネジ"	TENSION ADJUST SCREW	
22-2-3	151030001	2	チヨウシハ"ネトメネジ"	SET SCREW	

J. 下軸関係 / Lower shaft mechanism / Untere welle /
 Mécanisme de l'arbre inférieur / Mecanismo de la eje inferior

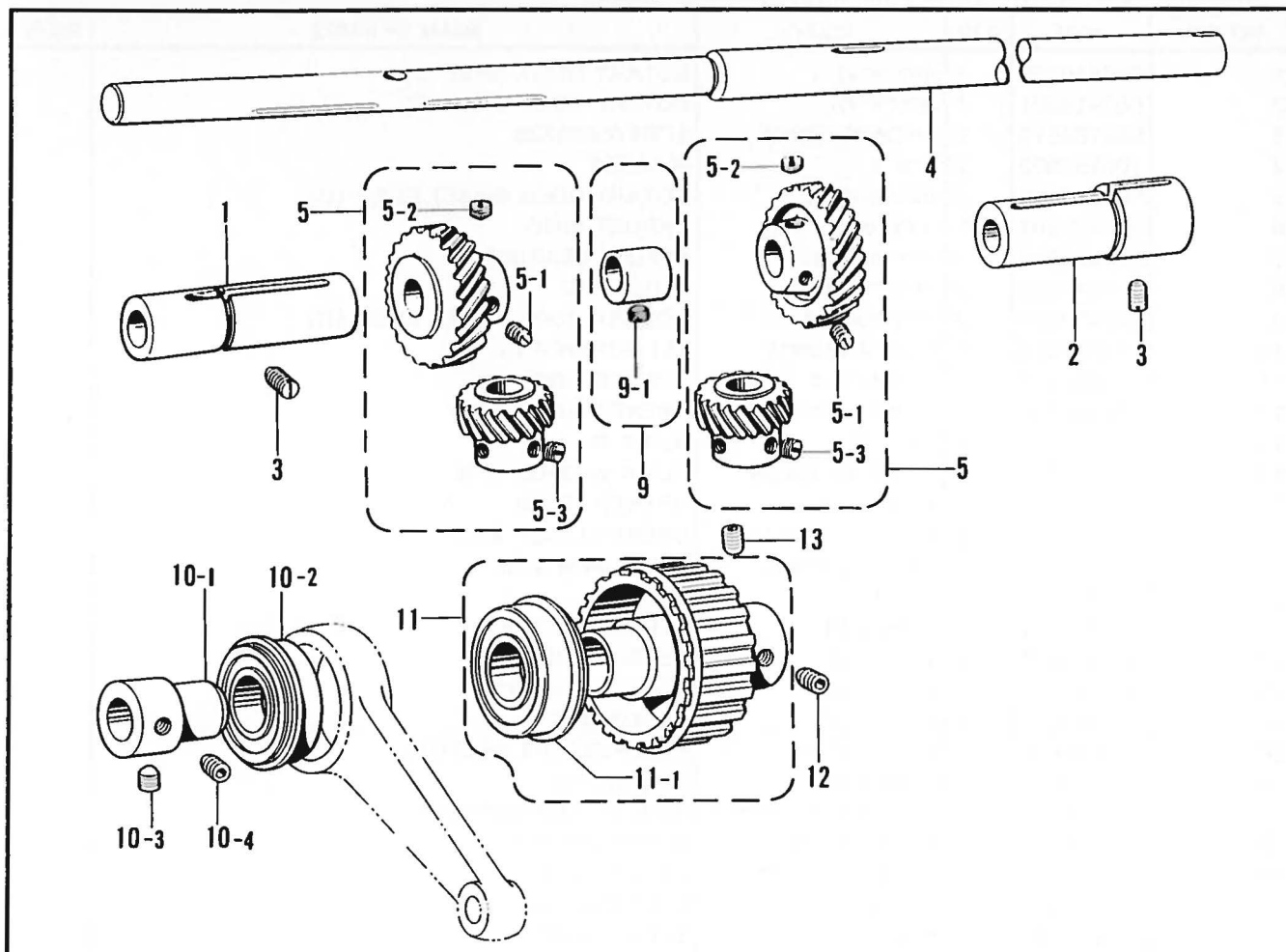

K. 特別注文部品 / Option parts / Sonderzubehör /
 Pièces en option / Piezas opcionas

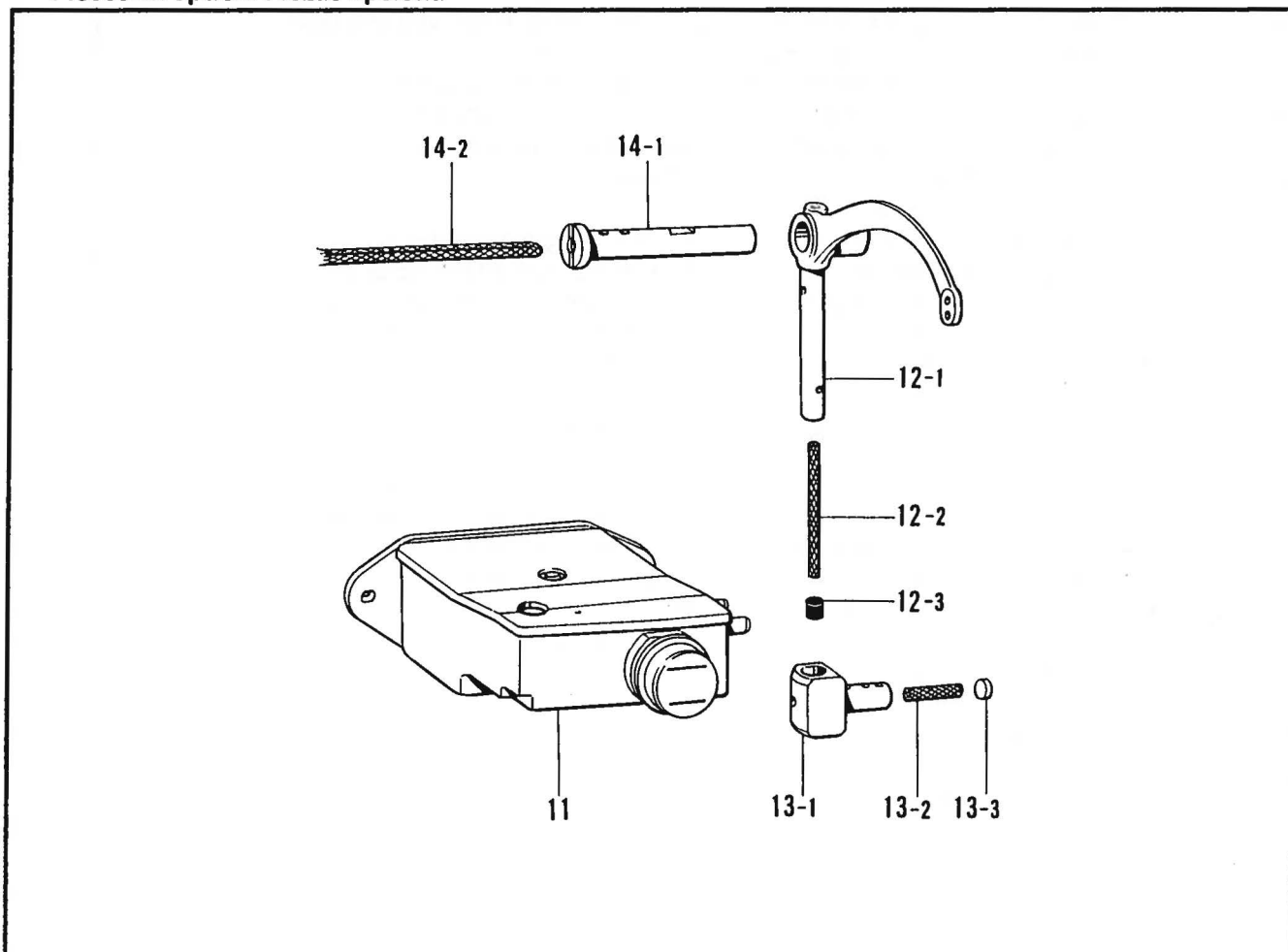

J. 下軸関係/Lower shaft mechanism/Untere welle/
Mécanisme de l'arbre inférieur/Mecanismo de la eje inferior

REF.NO.	CODE	Q'TY	ヒンメイ	NAME OF PARTS	RMKS
1	148503000	1	カマト"タ"イメタルL	ROTARY HOOK BASE BUSH (L)	
2	148502000	1	カマト"タ"イメタルR	ROTARY HOOK BASE BUSH (R)	
3	013781012	2	トメネジ"6.35クホ"ミ	SET SCREW 6.35	
4	S07438001	1	シタシ"ク	LOWER SHAFT	
5	S12445001	2	スパ"イラルキ"ヤクミA	SPIRAL GEAR ASSEMBLY (A)	
5-1	112684001	2	トメネジ"6.35	SET SCREW 6.35	
5-2	100251001	4	トメネジ"6.35	SET SCREW 6.35	
5-3	131007001	6	トメネジ"6.35クホ"ミ	SET SCREW 6.35	
9	181486001	1	ジ"ヨウケ"ヘンシンリンクミ	VERTICAL FEED ECCENTRIC WHEEL ASSEMBLY	
9-1	112684001	1	トメネジ"6.35	SET SCREW 6.35	
10	S07446001	1	タマシ"クウケクミ	BALL BEARING ASSEMBLY	
10-1	S07447001	1	タマシ"クウケフ"ツシユ	BALL BEARING BUSH	
10-2	072600480	1	タマシ"クウケ6004ZZNR	BALL BEARING 6004ZZNR	
10-3	148821001	1	アナトメネジ"6.35トガ"リ	SET SCREW 6.35	
10-4	014771022	1	アナトメネジ"6.35クホ"ミ	SET SCREW 6.35	
11	S07442001	1	タイミン"グ"プ"ー"リDクミ	TIMING PULLEY (D) ASSEMBLY	
11-1	158115001	1	タマシ"クウケ6204ZZNR	BALL BEARING 6204ZZNR	
12	148821001	1	アナトメネジ"6.35トガ"リ	SET SCREW 6.35	
13	014771022	1	アナトメネジ"6.35クホ"ミ	SET SCREW 6.35	

K. 特別注文部品/Option parts/Sonderzubehör/
Pièces en option/Piezas opciona

REF.NO.	CODE	Q'TY	ヒンメイ	NAME OF PARTS	RMKS
11	S13162009	1	オイルタンククミ	OIL TANK ASSEMBLY	
13	S13160001	1	テンビ"ンスヘ"リコ2クミ	THREAD TAKE-UP SLIDE BLOCK 2 ASSEMBLY	
13-1	S07338001	1	テンビ"ンスヘ"リコ	THREAD TAKE-UP SLIDE BLOCK	
13-2	114693001	1	クミヒモ (L=30)	WICK (L=30)	
13-3	113024000	1	クミヒモフタ	PUSHER	
14	S14506001	1	テンビ"ンシ"ククミ	THREAD TAKE-UP SHAFT ASSEMBLY	
14-1	S07334001	1	テンビ"ンシ"ク	THREAD TAKE-UP SHAFT	
14-2	113653000	1	クミヒモ	WICK (L=130)	
< -1, -3 >					
12	S13156001	1	テンビ"ンS3クミ	THREAD TAKE-UP (S3) ASSEMBLY	
12-1	S07336001	1	テンビ"ン	THREAD TAKE-UP	
12-2	S03289001	1	クミヒモ4X4	WICK 4X4 (L=40)	
12-3	142274009	1	メクラセン	OIL CAP	
< -5 >					
12	S13157001	1	テンビ"ンS5クミ	THREAD TAKE-UP (S5) ASSEMBLY	
12-1	S07337001	1	テンビ"ン	THREAD TAKE-UP	
12-2	S03289001	1	クミヒモ4X4	WICK 4X4 (L=40)	
12-3	142274009	1	メクラセン	OIL CAP	

L. 給油潤滑関係/Lubrication/Schmierung/
Lubrification/Lubrificación

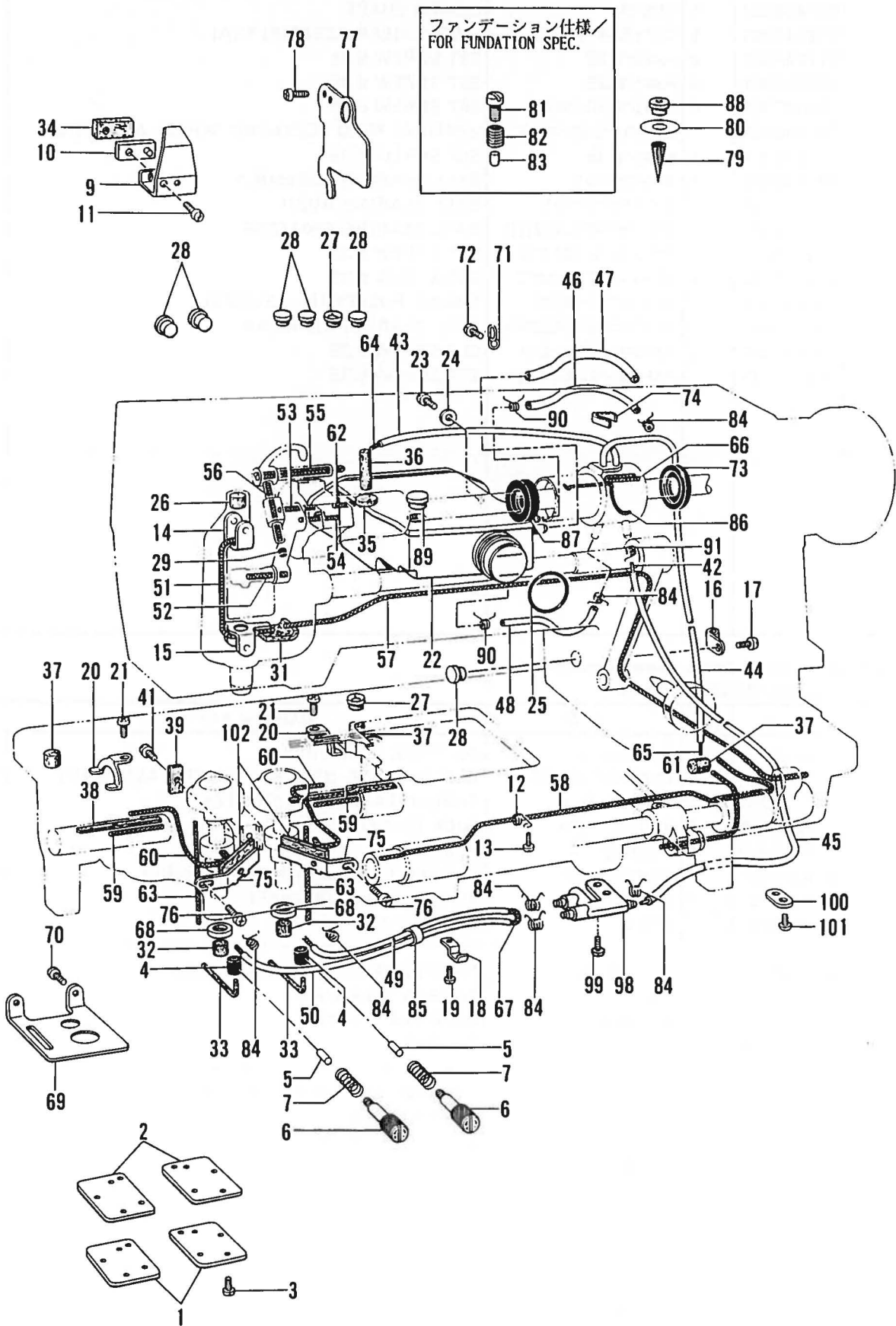

L. 給油潤滑関係/Lubrication/Schmierung/
Lubrification/Lubricación

REF.NO.	CODE	Q'TY	ヒンメイ	NAME OF PARTS	RMKS
1	S07448001	2	カマト"タ"イフタ	ROTARY HOOK BASE COVER	
2	S07449000	2	カマト"タ"イハ"ツキン	ROTARY HOOK BASE PACKING	
3	062670812	8	ナヘ"コ357-40X8	SCREW 357X8	
4	S07477000	2	ゴ"ムリング"	RUBBER RING	
5	S07478000	2	ゴ"ムオサエ	RUBBER PRESSER	
6	S07479101	2	オイルチヨウセツネジ"	ADJUST SCREW	
7	S16114001	2	オイルチヨウセツハ"ネ	SPRING	
9	150988001	1	オイルヨクイタ	OIL STOPPER PLATE	
10	112717001	1	オイルヨクイタオサエカネ	OIL STOPPER PLATE PRESSER	
11	062711212	1	ナヘ"コ476-32X12	SCREW 476X12	
12	112743001	1	クミヒモササエ	WICK SUPPORT	
13	062670512	1	ナヘ"コ357-40X5	SCREW 357X5	
14	112719001	1	フェルトオサエU	FELT SUPPORT (U)	
15	112720101	1	フェルトオサエD	FELT SUPPORT (D)	
16	112739001	1	クミヒモササエ	WICK SUPPORT	
17	062670512	1	ナヘ"コ357-40X5	SCREW 357X5	
18	142268001	1	コート"オサエL	CORD HOLDER (L)	
19	062670512	1	ナヘ"コ357-40X5	SCREW 357X5	
20	S07471001	2	ヒモササエ	WICK HOLDER	
21	062670512	2	ナヘ"コ357-40X5	SCREW 357X5	
22	S07450109	1	オイルタンククミ	OIL TANK ASSEMBLY	
23	062711012	2	ナヘ"コ476-32X10	SCREW 476X10	
24	025710232	2	ヒラサ"カ"ネチユウ4.76	PLAIN WASHER 4.76	
25	081030070	1	Oリング"P30	O RING P30	
26	148394000	1	ハリホ"ウセン	NEEDLE BAR CAP	
27	140890009	2	オイルカツプ"	OIL CAP	
28	*	*	メクラセン	OIL CAP	
29	142274009	2	メクラセン	OIL CAP	
31	S07474000	1	フェルト	FELT	
32	151927001	2	クラッチフェルト	CLUTCH FELT	
33	S07476000	2	フェルト	FELT	
34	148762001	1	テンヒ"ンフェルト	FELT	
35	112734001	1	ウフシ"クメタルLフェルト	UPPER SHAFT BUSH (L) FELT	
36	S07571000	1	フェルト	FELT	
37	112753001	3	フェルト	FELT	
38	113362001	2	カマト"タ"イメタルRフェルト	ROTARY HOOK BASE BUSH (R) FELT	
40	112759001	1	オクリタ"イフタマタフェルト	FELT	
41	100257010	1	シメネジ"3.57	SCREW 3.57	
42	S07460100	1	ワイヤー	WIRE	
43	S07453000	1	ヒ"ニールチューブ"	OIL TUBE	
44	S07454000	1	ヒ"ニールチューブ"	OIL TUBE	
45	S07455100	1	ヒ"ニールチューブ"	OIL TUBE	
46	S07456000	1	ヒ"ニールチューブ"	OIL TUBE	
47	S07457100	1	ヒ"ニールチューブ"	OIL TUBE	
48	S07810000	1	ヒ"ニールチューブ"	OIL TUBE	
49	S07458100	1	ヒ"ニールチューブ"	OIL TUBE	
50	S07459100	1	ヒ"ニールチューブ"	OIL TUBE	
51	S07465000	1	クミヒモ (L=200)	WICK (L=200)	
52	112728001	1	クミヒモ (L=50)	WICK (L=50)	
53	114693001	1	クミヒモ (L=30)	WICK (L=30)	
54	112735000	1	クミヒモ (L=45)	WICK (L=45)	
55	113653000	1	クミヒモ (L=130)	WICK (L=130)	
56	S03289001	1	クミヒモ4X4 (L=40)	WICK 4X4 (L=40)	
57	112736000	1	クミヒモ (L=440)	WICK (L=440)	
58	152974001	1	クミヒモ4X4 (L=350)	WICK 4X4 (L=350)	
59	S07461000	2	クミヒモ (L=32)	WICK (L=32)	
60	108802001	2	クミヒモ4X4 (L=250)	WICK 4X4 (L=250)	
61	152973001	1	クミヒモ4X4 (L=170)	WICK 4X4 (L=170)	
62	S07462000	1	クミヒモ (L=25)	WICK (L=25)	
63	S07463000	2	クミヒモ (L=70)	WICK (L=70)	
64	153920001	1	クミヒモ4X4 (L=300)	WICK 4X4 (L=300)	
65	152974001	1	クミヒモ4X4 (L=350)	WICK 4X4 (L=350)	

L. 給油潤滑関係/Lubrication/Schmierung/
Lubrification/Lubrificación

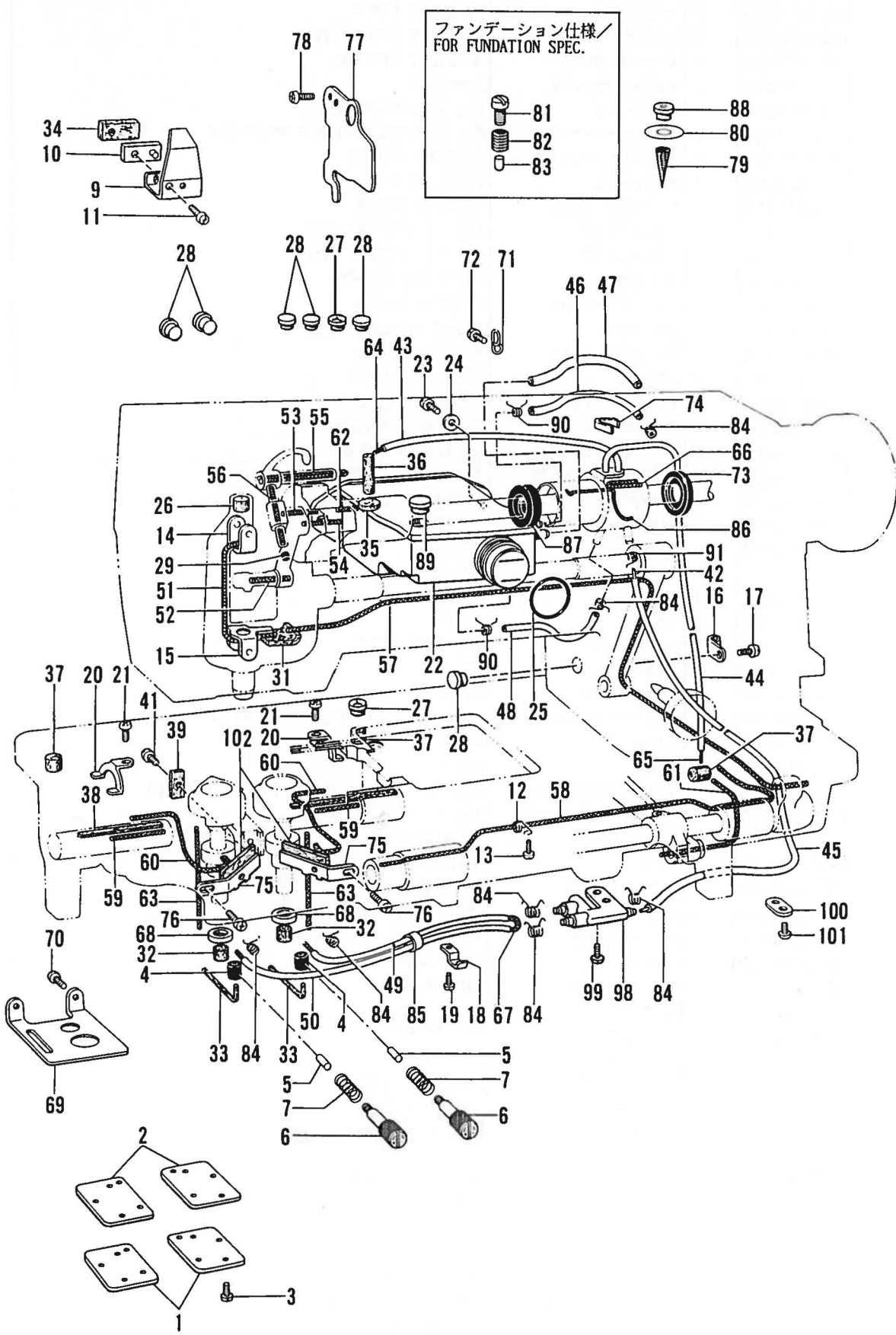

L. 給油潤滑関係/Lubrication/Schmierung/
Lubrification/Lubrificación

REF.NO.	CODE	Q'TY	品名	NAME OF PARTS	RMKS
66	S03289001	1	クミヒモ4X4 (L=40)	WICK 4X4 (L=40)	
67	S07464100	1	クミヒモ (L=530)	WICK (L=530)	
68	156070002	2	スペーサー	SPACER	
69	S07466001	1	ダストプレート	DUST PROTECTOR	
70	062670512	2	ナヘ"コ357-40X5	SCREW 357X5	
71	S07467001	1	チューブ"ササエ	TUBE SUPPORT	
72	062680812	1	ナヘ"コ437-40X8	SCREW 437X8	
73	S07468000	1	オイルシール	OIL SEAL	
74	S07469001	1	チューブ"カシメ	TUBE CALKING	
75	S21195001	2	フェルトササエ	FELT SUPPORT	
76	062670512	2	ナヘ"コ357-40X5	SCREW 357X5	
77	S07472001	1	シャヘイハ"ン	INTERRUPT PLATE	
78	062670512	2	ナヘ"コ357-40X5	SCREW 357X5	
79	S07473000	1	オイルフィルター	OIL FILTER	
80	S07481009	1	オイルシート	OIL MARK SEAT	
81	145619001	1	シメネジ"6.35	SCREW 6.35	
82	S07482001	1	キユウチヨウセツハ"ネ	SPRING	
83	S07478000	1	ゴムオサエ	RUBBER PRESSER	
84	S07876001	7	チューブ"ストツハ"ー	TUBE CLAMP	
85	146253000	1	チューブ"	OIL TUBE	
86	S09369000	1	クミヒモ (L=70)	WICK (L=70)	
87	S09364000	1	オイルシール	OIL SEAL	
88	112758009	1	ヘ"ット"オイルフタ	OIL CAP	
89	104821009	1	メクラセン	OIL CAP	
90	S07876001	2	チューブ"ストツハ"ー	TUBE CLAMP	
91	S07876001	1	チューブ"ストツハ"ー	TUBE CLAMP	
98	S14189000	1	ターミナル	TERMINAL	
99	062670612	2	ナヘ"コ357-40X6	SCREW 357X6	
100	146536001	1	オクリホ"タンシ"クササエ	FEED ADJUST SHAFT SUPPORT	
101	062670612	1	ナヘ"コ357-40X6	SCREW 357X6	
102	S21196001	2	フェルト	FELT	

M. 糸通シ関係 / Threading mechanism / Fadenführungsrichtung /
 Mécanisme de l'enfilage / Mecanismo de la enhebrado

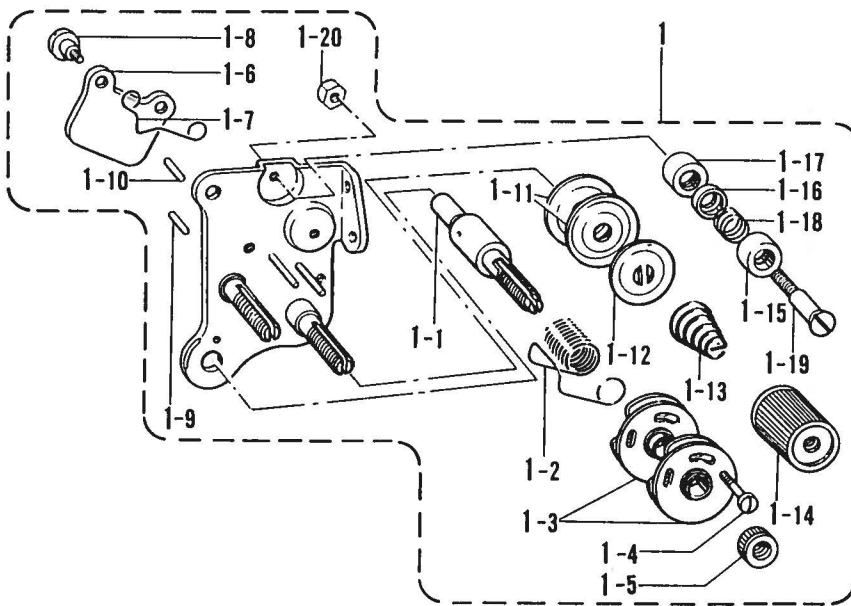
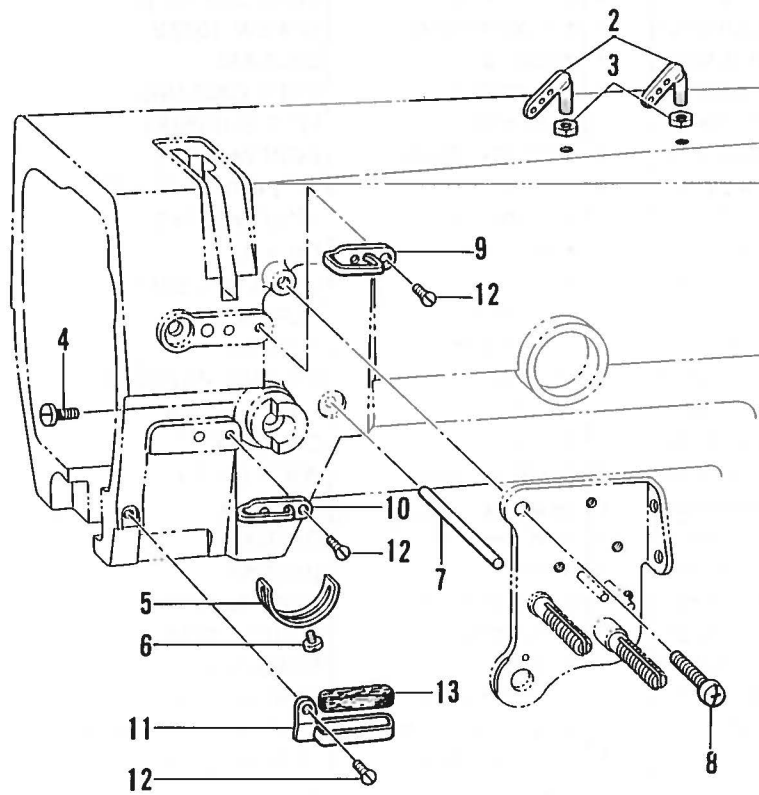

M. 糸通シ関係/Threading mechanism/FadenführungsVorrichtung/
 Mécanisme de l'enfilage/Mecanismo de la enhebrado

REF.NO.	CODE	Q'TY	ヒンメイ	NAME OF PARTS	RMKS
1	S07489109	1	ウワイトチヨウシクミ	UPPER THREAD TENSION ASSEMBLY	
1-1	144680001	1	チヨウシジ"ク	TENSION STUD	
1-2	155491001	1	イトトリハ"ネ	SPRING	
1-3	108254001	2	イトトリハ"ネアンナイクミ	SPRING GUIDE ASSEMBLY	
1-4	144682001	1	シメネジ"2.38	SCREW 2.38	
1-5	108265009	1	イトチヨウシナツト	TENSION NUT	
1-6	S07487001	1	イトユルメイタ	TENSION RELEASE PLATE	
1-7	118320001	1	イトユルメハ"ネ	SPRING	
1-8	112712001	2	タ"ンネジ"3.57	STUD SCREW 3.57	
1-9	158769001	1	イトユルヒ"ンR	PIN (R)	
1-10	S07488001	1	イトユルヒ"ンL	PIN (L)	
1-11	145446001	4	イトチヨウシサラ	TENSION DISC	
1-12	159805001	2	イトチヨウシサラオサエ	TENSION DISC PRESSER	
1-13	S07490001	2	イトチヨウシハ"ネ	TENSION SPRING	
1-14	149566009	2	イトチヨウシナツト	TENSION NUT	
1-15	144685001	2	イトアンナイフタ	THREAD GUIDE CAP	
1-16	144686001	2	イトアンナイサラ	THREAD GUIDE DISC	
1-17	144687001	2	イトアンナイタ"イ	THREAD GUIDE BRACKET	
1-18	144688001	2	イトアンナイハ"ネ	SPRING	
1-19	144689101	2	イトアンナイタ"ンネジ"	THREAD GUIDE STUD SCREW	
1-20	021670102	2	ナツト1 シユ3.57	NUT 3.57	
2	140527001	2	ミツメイトカケ	THREAD RETAINER	
3	150553003	2	ナツト5.95	NUT 5.95	
4	100064002	1	シメネジ"3.57	SCREW 3.57	
5	112709001	1	イトトリハ"ネストツハ"	STOPPER	
6	062670512	1	ナヘ"コ357-40X5	SCREW 357X5	
7	S07493001	1	イトユルメジ"ク	TENSION RELEASE BAR	
8	062680812	1	ナヘ"コ437-40X8	SCREW 437X8	
9	108266001	1	ア-ムイトアンナイU	ARM THREAD GUIDE (U)	
10	112658001	1	ア-ムイトアンナイM	ARM THREAD GUIDE (M)	
11	112715001	1	ア-ムイトアンナイD	ARM THREAD GUIDE (D)	
12	108960002	3	サラネジ"3.57	SCREW 3.57	
13	114941001	1	ア-ムイトアンナイフェルト	FELT	

Z. 付属品関係 / Accessories / Zubehör /
Accessoires / Accesorios

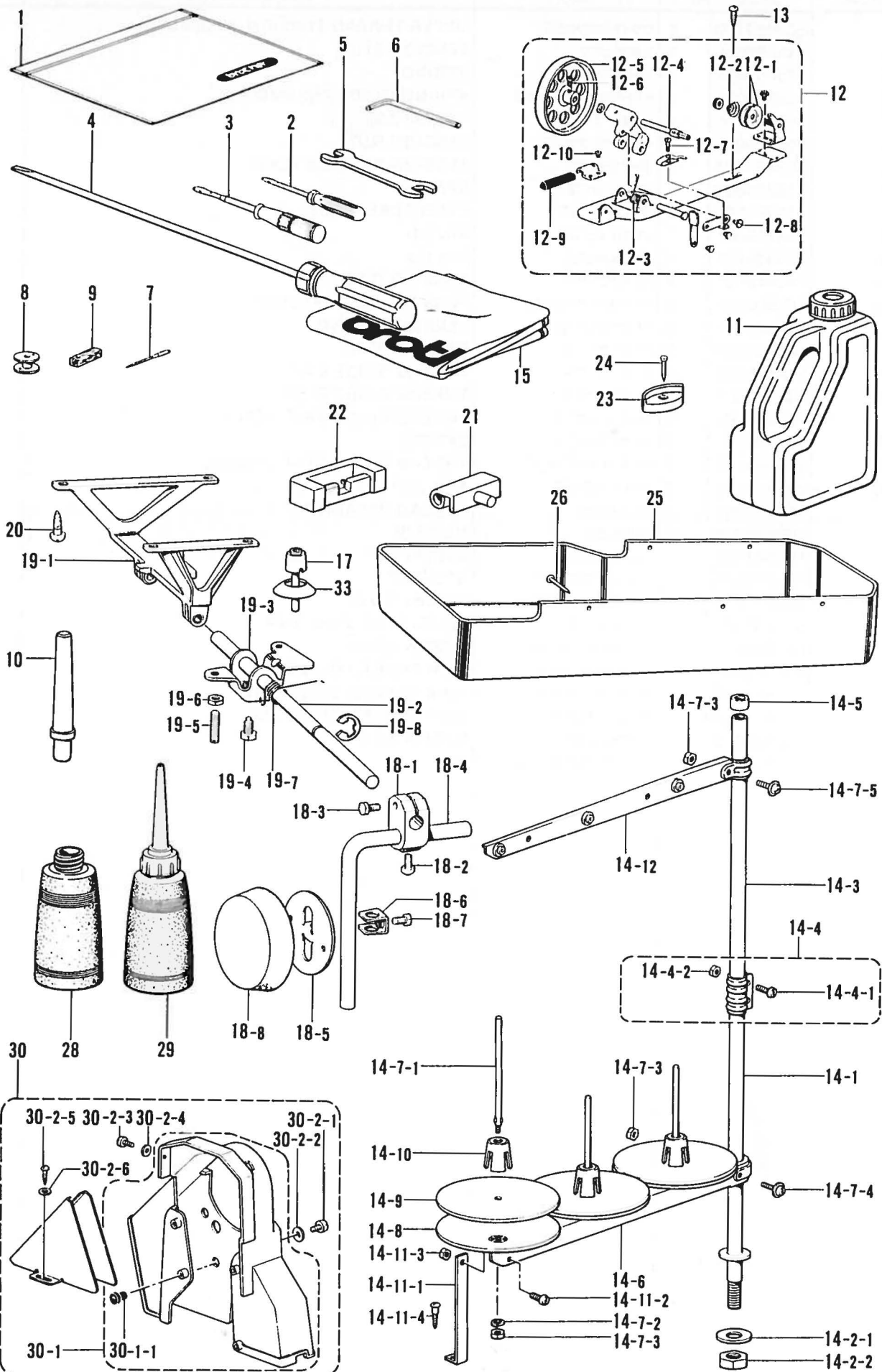

◎ 付属品の明細は変更することがあります。
 ◎ The details of included accessories are subject to change.
 ◎ Änderungen in der Aufstellung der Mitgelieferten Zubehöre sind vorbehalten.

◎ Les détails des accessoires inclus sont sujets a des changements.
 ◎ Los detalles de los accesorios incluidos pueden variar.

Z. 付属品関係/Accessories/Zubehör/
Accessoires/Accessorios

REF.NO.	CODE	Q'TY	ヒンメイ	NAME OF PARTS	RMKS
1	122991001	1	フゾクヒンホ ^o リフクロ	ACCESSORY BAG	
2	142443001	1	ネジ ^o マワシ1.9X52	SCREW DRIVER 1.9X52	
3	118837001	1	ネジ ^o マワシ3.4X70	SCREW DRIVER 3.4X70	
4	S17774001	1	ネジ ^o マワシ4.7X250	SCREW DRIVER 4.7X250	
5	107780001	1	スパ ^o ナ10X12	SPANNER 10X12	
6	142002001	1	6カクホ ^o ウススパ ^o ナ2	HEXAGONAL WRENCH 2	
7	*	8	ミシンハリDPX5	NEEDLE DPX5	
8	112781101	4	ホ ^o ビ ^o ン	BOBBIN	
9	114941001	2	アームイトアンナイフエルト	FELT	
10	100477009	1	マクラ	HEAD REST	
11	154702001	1	オイルタンク	OIL TANK	
12	117963109	1	イトマキキクミ	BOBBIN WINDER ASSEMBLY	
12-1	145446001	2	イトチヨウシサラ	TENSION DISC	
12-2	100401001	1	イトチヨウシハ ^o ネ	TENSION SPRING	
12-3	117969001	1	イトマキジ ^o クウカエリハ ^o ネ	SPRING	
12-4	117970001	1	イトマキジ ^o ク	BOBBIN WINDER SHAFT	
12-5	S18634009	1	イトマキクルマ	BOBBIN WINDER WHEEL	
12-6	100366002	1	マルヒラトメネジ ^o 4.37X5	SET SCREW 4.37X5	
12-7	100657001	1	シメネジ ^o 3.18	SCREW 3.18	
12-8	100659001	1	ダン ^o ネジ ^o 3.18	STUD SCREW 3.18	
12-9	100662001	1	イトマキクルマカイテント ^o メ	BOBBIN WINDER WHEEL STOPPER	
12-10	S01297001	1	シメネジ ^o 3.57X3.5	SCREW 3.57X3.5	
13	100666002	2	マルモクネジ ^o 5.5X20	SCREW 5.5X20	
14	S02766009	1	イトタテダ ^o イクミ3D	COTTON STAND ASSEMBLY (3D)	
14-1	156112003	1	コラムハ ^o イフ ^o D	COLUMN PIPE (D)	
14-2	S02775001	1	ハ ^o イフ ^o ネジ ^o セットA	PIPE SCREW SET (A)	
14-2-1	150206002	1	ヒラサ ^o カ ^o ネ16	PLAIN WASHER 16	
14-2-2	150191002	1	6カクナツト5/8	NUT 5/8	
14-3	150172003	1	コラムハ ^o イフ ^o	COLUMN PIPE	
14-4	150106003	1	コラムシ ^o ヨイントクミ	COLUMN JOINT ASSEMBLY	
14-4-1	062501406	2	ナ ^o ヘ ^o コ5X14	SCREW 5X14	
14-4-2	021500106	2	1シユナツト5	NUT 5	
14-5	150174000	1	コラムキヤツ ^o	COLUMN CAP	
14-6	S02779009	1	スプ ^o ールホルタ ^o -3	SPOOL HOLDER 3	
14-7	S02782001	1	スプ ^o ールネジ ^o セット3	SPOOL SCREW SET 3	
14-7-1	150179002	3	スプ ^o ールシ ^o クB	SPOOL SHAFT (B)	
14-7-2	028050246	3	ハ ^o ネサ ^o カ ^o ネ2-5	SPRING WASHER 2-5	
14-7-3	021500106	5	1シユナツト5	NUT 5	
14-7-4	050503006	1	ナ ^o ヘ ^o コヒラサ ^o 5X30	WASHER SCREW 5X30	
14-7-5	050501406	1	ナ ^o ヘ ^o コヒラサ ^o 5X14	WASHER SCREW 5X14	
14-8	150180001	3	ウケサ ^o ラ	SPOOL STAND BASE	
14-9	150182000	3	スプ ^o ールマット	SPOOL MAT	
14-10	126863001	3	スプ ^o ールクツシヨソ	SPOOL CUSHION	
14-11	S02784009	1	ホルタ ^o -ササエAセット	HOLDER SUPPORT (A) SET	
14-11-1	150188009	1	スプ ^o ールホルタ ^o -ササエA	SPOOL HOLDER SUPPORT (A)	
14-11-2	062501006	1	ナ ^o ヘ ^o コ5X10	SCREW 5X10	
14-11-3	021500106	1	1シユナツト5	NUT 5	
14-11-4	031452206	1	マルモク45X22	SCREW 45X22	
14-12	S02788009	1	スレツト ^o ハンガ ^o ークミ3	THREAD HANGER ASSEMBLY 3	
15	144222001	1	トウフ ^o カハ ^o -	HEAD COVER	
17	145573000	1	ヒサ ^o アケ ^o オシホ ^o ウ	KNEE LIFTER COMPLYING BAR	
18	181427001	1	ヒサ ^o アテクミ	KNEE LIFTER ASSEMBLY	
18-1	146039001	1	ヒサ ^o アテツキ ^o テ	KNEE LIFTER JOINT	
18-2	100463001	1	4カクホ ^o ルト7.94	BOLT 7.94	
18-3	017762013	1	ホ ^o ルト5.95X20	BOLT 5.95X20	
18-4	104619002	1	ヒサ ^o アケ ^o タテシ ^o ク	KNEE LIFTER BAR	
18-5	114966001	1	ヒサ ^o アテ	KNEE LIFTER PLATE	
18-6	114967001	1	ヒサ ^o アテストツハ ^o	KNEE LIFTER PLATE STOPPER	
18-7	110087001	1	ホ ^o ルト5.95	BOLT 5.95	
18-8	140503001	1	ヒサ ^o アテカハ ^o -	KNEE LIFTER PLATE COVER	
19	S07559101	1	ヒサ ^o アケ ^o クミ	KNEE LIFTER ASSEMBLY	
19-1	S07560000	1	ヒサ ^o アケ ^o フ ^o ラケツト	KNEE LIFTER BRACKET	

Z. 付属品関係/Accessories/Zubehör/
Accessoires/Accesorios

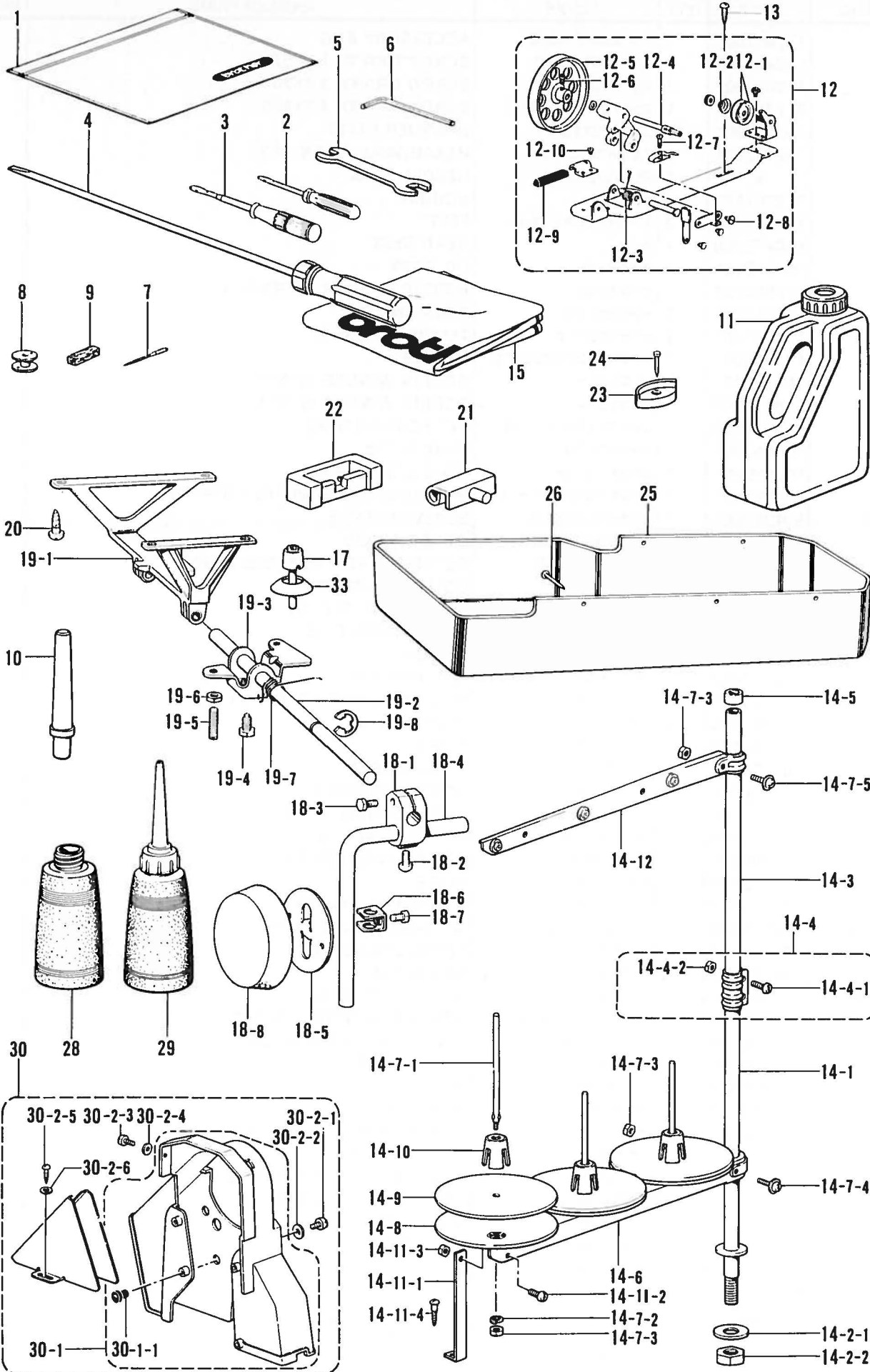

◎ 付属品の明細は変更することがあります。
 ◎ The details of included accessories are subject to change.
 ◎ Änderungen in der Aufstellung der Mitgelieferten Zubehöre sind vorbehalten.

◎ Les détails des accessoires inclus sont sujets à des changements.
 ◎ Los detalles de los accesorios incluidos pueden variar.



Z. 付属品関係/Accessories/Zubehör/
Accessoires/Accessorios

REF NO.	CODE	Q'TY	ヒンメイ	NAME OF PARTS	RMKS
19-2	146036101	1	ヒサ"アケ"ヨコジ"ク	KNEE LIFTER SHAFT	
19-3	146037001	1	ヒサ"アケ"	KNEE LIFTER	
19-4	146367001	1	ボ"ルト5.95	BOLT 5.95	
19-5	104885101	2	トメネジ"5.95	SET SCREW 5.95	
19-6	100022004	2	ナツト5.95	NUT 5.95	
19-7	146038001	1	ヒサ"アケ"ネジ"リハ"ネ	TWIST SPRING	
19-8	146293001	1	トメワE10	STOP RING E10	
20	100666002	4	マルモクネジ"5.5X20	SCREW 5.5X20	
21	143882001	2	トウフ"ヒンシ"	HEAD HINGE	
22	143910009	2	トウフ"ヒンシ"ウケゴ"ム	RUBBER CUSHION	
23	148890109	4	トウフ"シキゴ"ム	HEAD CUSHION	
24	109714000	8	クキ"	NAIL	
25	S07561009	1	オイルパン	OIL PAN	
26	109714000	5	クキ"	NAIL	
28	114486002	1	ホ"リオイルータイ	OILER	
29	114483002	1	ホ"リオイルークミ	OILER ASSEMBLY	
30	183480009	1	へ"ルトカハ"ークミ	BELT COVER ASSEMBLY	
30-1	S08468009	1	へ"ルトカハ"ーカラークミ	BELT COVER COLLAR ASSEMBLY	
30-1-1	S07660000	4	ゴ"ムカラー	RUBBER COLLAR	
30-2-1	062712012	4	ナへ"コ476-32X20	SCREW 476X20	
30-2-2	025050332	4	ヒラサ"ガ"ネタ"イ5	PLAIN WASHER 5	
30-2-3	062680812	1	ナへ"コ437-40X8	SCREW 437X8	
30-2-4	025680232	1	ヒラサ"ガ"ネチユウ4.37	PLAIN WASHER 4.37	
30-2-5	100666002	2	マルモクネジ"5.5X20	SCREW 5.5X20	
30-2-6	025750132	2	ヒラサ"ガ"ネシヨウ5.56	PLAIN WASHER 5.56	
33	S08188001	1	スカート	SKIRT	

仕様別部品一覧表 / DIFFERENT PARTS LIST / ZUBEHÖRLISTE /
 LISTE DES PIECES ACCESSOIRES / LISTA DE PIEZAS ACCESORIAS

REF.NO.	サブクラス SUB CLASS ヒンメイ PARTS	-1 ファンデーションシヨウ FOR FOUNDATION SPEC.	-3	-5		
A-9	ミシンハリDPX5 (#) ----- NEEDLE DPX5 (#)	107415011(11)	107415014(14)	107415022(22)		
B-21	テンビン ----- THREAD TAKE-UP	S07336001	←	S07337001		
D-1	ヘンシンリンクミ ----- ECCENTRIC WHEEL ASSEMBLY	112673001	←	149767001		
G-4	サラネジ"4.37 ----- SCREW 4.37	117160001	10032004	←		
Z-7	ミシンハリDPX5 (#) ----- NEEDLE DPX5 (#)	107415011(11)	107415014(14)	107415022(22)		

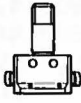
ゲージ部品一覧表/GAUGE PARTS LIST/LEHRENLISTE/
LISTE DE PIÉCES D'ECARTEMENT/LISTE DE PIEZAS CALIBRADORAS

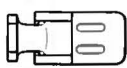
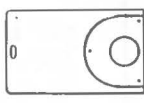
針幅 Needle Gauge	仕様 Sub-class	a-1	a-2	a-7	a-5	A-13
		ハリダキクミ Needle Clamp Assembly 	ハリイタ Needle Plate 	オクリバ Feed Dog 	オサエクミ Presser Foot Assembly 	スベリイタLクミ Slide Plate (L) Assembly 
縦2本縫 Tandem (0.5mm)	-3	158801-001	142111-001	142110-001	142105-001	S07318-201
1/16" (1.6mm)	-3	158808-001	142111-001	151078-001	151076-001	
1/8" (3.2mm)	-1 (ファンデーション仕様 for Foundation Spec)	158794-101	117370-001	117366-001	114948-001	
	-3		114950-001	114951-001		
	-5		117369-001	●158430-001		
5/32" (4.0mm)	-3	158796-101	116503-001	116509-001	116502-001	
	-5		150850-001			
3/16" (4.8mm)	-1 (ファンデーション仕様 for Foundation Spec)	158791-101	117158-001	117134-001	112638-001	
	-3		112603-001	112659-001 ★S21149-001		
	-5		117133-001	●S13588-001		
1/4" (6.4mm)	-1 (ファンデーション仕様 for Foundation Spec)	158792-101	117368-001	117365-001	112642-001	
	-3		112604-001	112660-001 ★S21150-001		
	-5		117367-001	●153882-001		
5/16" (7.9mm)	-3	158793-101	112605-001	112661-001	112645-001	
	-5		144882-001			
3/8" (9.5mm)	-3	158798-101	116506-101	116510-101	116498-001	
	-5		144881-101	●153887-001		
7/16" (11.1mm)	-3	158809-101	151596-001	151598-001	151597-001	
1/2" (12.7mm)	-3	158797-101	116505-001	116511-001	116499-001	
	-5		S09365-001	●153892-001		
5/8" (15.9mm)	-3	158795-101	116507-001	116512-001	116500-001	
	-5		159577-001	●153897-001		
1" (25.4mm)	-3	158805-101	147176-001	147178-001 ●153907-001	147177-001	
1-1/4" (31.8mm)	-3	158799-101	116504-001	116508-001	116501-001	S07323-201
1-1/2" (38.1mm)	-3	158800-101	118945-001	118947-001	118946-001	

- 印は、極厚物用です。針穴寸法は右図のようになってます。
- Needle hole dimensions for heavy materials (indicated by a ●) are shown in the figure at the right.
- Die Nadellochmessungen für dicke Materialien (mit ● bezeichnet) sind in der nebenstehenden Abbildung angegeben.
- Les dimensions du trou de l'aiguille pour les tissus épais (indiqué avec ●) sont indiquées dans l'illustration à droite.
- Las dimensiones para el orificio de aguja cuando se cosen materiales pesados (indicados por un asterisco ●) son las que se indican a la derecha.

- ★ 印は針穴寸法が2mm×3mmです。
- Needle hole dimensions are 2 mm × 3 mm (indicated by a ★).
- Nadelöhrmessungen 2 mm × 3 mm (mit ★ bezeichnet).
- Les dimensions du chas de l'aiguille sont de 2 mm × 3 mm (indiqué par le symbole ★).
- Las dimensiones del orificio para la aguja son de 2 mm × 3 mm (se indica mediante un ★).

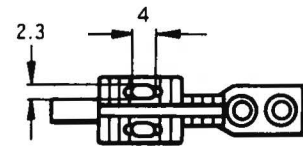

< 特別注文部品 / OPTION PARTS >

アンナイツキオサエクミ / Presser Foot Assembly with Guide		
	1/8" (3.2mm)	149311-001
	3/16" (4.8mm)	117281-001
	1/4" (6.4mm)	149312-001

索引/INDEX/VERZEICHNIS/
INDEX/INDICE

CODE	REF.NO.	PAGE
S01297001	Z - 12-10	20
S01304001	C - 10	4
	D - 7-1	4
S02499009	A - 7	2
S02766009	Z - 14	20
S02775001	Z - 14-2	20
S02779009	Z - 14-6	20
S02782001	Z - 14-7	20
S02784009	Z - 14-11	20
S02788009	Z - 14-12	20
S03289001	K - 12-2	12
	L - 56	14
	L - 66	16
S07316009	A - 3	2
S07317001	A - 4	2
S07319101	A - 13-1	2
S07320000	A - 13-2	2
	A - 14-2	2
S07325201	A - 14	2
S07326101	A - 14-1	2
S07328000	A - 15-1	2
S07329001	B - 5	2
S07330101	B - 3	2
S07334001	B - 22	2
	K - 14-1	12
S07336001	K - 12-1	12
S07337001	K - 12-1	12
S07338001	B - 24	2
	K - 13-1	12
S07339009	B - 26	2
S07344101	C - 11	4
S07345001	E - 7	6
S07346101	E - 6	6
S07347001	E - 9	6
S07348001	E - 16	6
S07349001	E - 17	6
S07350001	E - 18	6
S07353001	E - 13	6
S07355001	E - 21	6
S07356001	E - 14	6
S07357001	E - 26	6
S07358001	E - 24	6
S07359001	E - 27	6
S07360001	D - 3	4
S07386001	F - 2	8
S07387001	F - 7	8
S07414201	H - 2	10
S07416201	H - 1	10
S07417001	H - 9	10
S07418001	H - 5	10
S07419001	H - 8	10
S07420000	H - 7	10
S07421001	H - 6	10
S07422101	H - 15	10
S07423101	H - 19	10
S07424001	H - 21	10
S07425001	H - 22	10
S07426001	H - 22	10
S07430001	H - 27	10
S07431001	H - 29	10
S07432001	H - 37	10
S07433001	H - 38	10
S07434001	H - 33	10
S07435001	H - 35	10
S07436001	H - 23	10
S07437001	H - 24	10
S07438001	J - 4	12

CODE	REF.NO.	PAGE
S07442001	J - 11	12
S07446001	J - 10	12
S07447001	J - 10-1	12
S07448001	L - 1	14
S07449000	L - 2	14
S07450109	L - 22	14
S07453000	L - 43	14
S07454000	L - 44	14
S07455100	L - 45	14
S07456000	L - 46	14
S07457100	L - 47	14
S07458100	L - 49	14
S07459100	L - 50	14
S07460100	L - 42	14
S07461000	L - 59	14
S07462000	L - 62	14
S07463000	L - 63	14
S07464100	L - 67	16
S07465000	L - 51	14
S07466001	L - 69	16
S07467001	L - 71	16
S07468000	L - 73	16
S07469001	L - 74	16
S07471001	L - 20	14
S07472001	L - 77	16
S07473000	L - 79	16
S07474000	L - 31	14
S07476000	L - 33	14
S07477000	L - 4	14
S07478000	L - 5	14
	L - 83	16
S07479101	L - 6	14
S07481009	L - 80	16
S07482001	L - 82	16
S07487001	M - 1-6	18
S07488001	M - 1-10	18
S07489109	M - 1	18
S07490001	M - 1-13	18
S07493001	M - 7	18
S07494001	G - 8	8
S07559101	Z - 19	20
S07560000	Z - 19-1	20
S07561009	Z - 25	22
S07571000	L - 36	14
S07658001	H - 26	10
S07660000	Z - 30-1-1	22
S07731001	H - 22-1	10
S07732001	H - 22-1	10
S07735001	H - 22-2	10
S07736001	H - 22-2	10
S07810000	L - 48	14
S07876001	L - 84	16
	L - 90	16
	L - 91	16
S08188001	Z - 33	22
S08468009	Z - 30-1	22
S09364000	L - 87	16
S09369000	L - 86	16
S09670001	B - 20	2
S11244001	G - 3	8
S12445001	J - 5	12
S13021001	H - 16	10
S13103009	E - 10	6
S13156001	K - 12	12
S13157001	K - 12	12
S13160001	K - 13	12
S13162009	K - 11	12

CODE	REF.NO.	PAGE
S13162009	K - 11	12
S14189000	L - 98	16
S14506001	K - 14	12
S16114001	L - 7	14
S17774001	Z - 4	20
S18634009	Z - 12-5	20
S21195001	L - 75	16
S21196001	L - 102	16
013710512	H - 10	10
013711012	H - 17	10
013761410	D - 2	4
013780710	B - 4	2
013781012	B - 2	2
	B - 23	2
	E - 2	6
	F - 3	8
	J - 3	12
014680422	E - 20	6
014680622	F - 10	8
	H - 32	10
	H - 36	10
014710522	E - 10-1	6
014771022	B - 15	2
	J - 10-4	12
	J - 13	12
016771032	B - 16	2
017762013	Z - 18-3	20
021500106	Z - 14-11-3	20
	Z - 14-4-2	20
	Z - 14-7-3	20
021660102	F - 15	8
021670102	E - 23	6
	M - 1-20	18
025050332	Z - 30-2-2	22
025060132	F - 13	8
025680132	H - 34	10
025680232	Z - 30-2-4	22
025710232	H - 14	10
	L - 24	14
025750132	Z - 30-2-6	22
028050246	Z - 14-7-2	20
028680242	C - 13	4
031452206	Z - 14-11-4	20
048040342	D - 5	4
	H - 30	10
050501406	Z - 14-7-5	20
050503006	Z - 14-7-4	20
062501006	Z - 14-11-2	20
062501406	Z - 14-4-1	20
062660412	D - 1-1	4
062661212	F - 14	8
062670512	B - 27	2
	L - 13	14
	L - 17	14
	L - 19	14
	L - 21	14
	L - 70	16
	L - 76	16
	L - 78	16
	M - 6	18
062670612	L - 101	16
	L - 99	16
062670812	C - 1-7	4
	E - 3	14
062671412	L - 22	6
062680812	A - 8	2
	L - 72	16

CODE	REF.NO.	PAGE
062680812	M - 8	18
	Z - 30-2-3	22
062681212	D - 9	4
062711012	H - 28	10
	L - 23	14
062711212	L - 11	14
062712012	Z - 30-2-1	22
062761412	F - 12	8
062782512	H - 3	10
072600480	J - 10-2	12
081030070	L - 25	14
100022004	Z - 19-6	22
100064002	M - 4	18
100197002	H - 4	10
100250001	B - 7	2
100251001	B - 12	2
	J - 5-2	12
100257010	L - 41	14
100366002	Z - 12-6	20
100401001	Z - 12-2	20
100463001	Z - 18-2	20
100477009	Z - 10	20
100657001	Z - 12-7	20
100659001	Z - 12-8	20
100662001	Z - 12-9	20
100666002	Z - 13	20
	Z - 20	22
	Z - 30-2-5	22
101268002	C - 8	4
101479001	D - 1-2	4
101706001	B - 11	2
	F - 6	8
102731004	C - 1-4	4
104619002	Z - 18-4	20
104821009	L - 89	16
104885101	Z - 19-5	22
105351002	C - 5	4
107780001	Z - 5	20
108254001	M - 1-3	18
108265009	M - 1-5	18
108266001	M - 9	18
108802001	L - 60	14
108960002	H - 25	10
	M - 12	18
109714000	Z - 24	22
	Z - 26	22
	Z - 18-7	20
110087001	H - 13	10
110161006	H - 13	10
112573101	B - 1	2
112574000	B - 6	2
112576001	B - 13	2
112577101	B - 9	2
112586001	B - 17	2
112588101	C - 1-1	4
112590001	C - 1-3	4
112592001	C - 1-6	4
112593001	C - 1-8	4
112594001	C - 2	4
112595000	C - 4	4
112596001	C - 6	4
112597001	C - 7	4
112598001	C - 9	4
112610101	A - 15	2
112656001	F - 11	8
112658001	M - 10	18
112673001	D - 1	4
112678000	D - 6-1	4

CODE	REF.NO.	PAGE
112684001	J - 5-1	12
	J - 9-1	12
112692101	H - 11	10
112700001	H - 26-1	10
112709001	M - 5	18
112712001	M - 1-8	18
112715001	M - 11	18
112717001	L - 10	14
112719001	L - 14	14
112720101	L - 15	14
112721001	C - 1-9	4
112728001	L - 52	14
112734001	L - 35	14
112735000	L - 54	14
112736000	L - 57	14
112739001	L - 16	14
112743001	L - 12	14
112753001	L - 37	14
112758009	L - 88	16
112759001	L - 40	14
112764001	C - 3	4
112781101	H - 40	10
	Z - 8	20
113014000	B - 10	2
113024000	B - 25	2
	K - 13-3	12
113050001	G - 6	8
113074001	F - 5	8
113362001	L - 38	14
113386000	A - 2	2
113653000	K - 14-2	12
	L - 55	14
113760001	A - 22	2
114483002	Z - 29	22
114486002	Z - 28	22
114693001	K - 13-2	12
	L - 53	14
114941001	M - 13	18
	Z - 9	20
114966001	Z - 18-5	20
114967001	Z - 18-6	20
115262001	D - 6	4
116010001	A - 16	2
116323001	G - 1-1	8
117850001	C - 14	4
117963109	Z - 12	20
117969001	Z - 12-3	20
117970001	Z - 12-4	20
118320001	M - 1-7	18
118718001	D - 4	4
118837001	Z - 3	20
118954000	D - 6-2	4
122991001	Z - 1	20
126863001	Z - 14-10	20
129984002	A - 6	2
131007001	J - 5-3	12
131226001	H - 39	10
139096001	E - 19	6
140503001	Z - 18-8	20
140527001	M - 2	18
140890009	L - 27	14
141207001	E - 3	6
141208001	E - 5	6
142002001	Z - 6	20
142112009	B - 19	2
142268001	L - 18	14
142274009	K - 12-3	12

CODE	REF.NO.	PAGE
142274009	L - 29	14
142403001	E - 8-2	6
142443001	Z - 2	20
143591001	F - 9	8
143882001	Z - 21	22
143910009	Z - 22	22
144222001	Z - 15	20
144680001	M - 1-1	18
144682001	M - 1-4	18
144685001	M - 1-15	18
144686001	M - 1-16	18
144687001	M - 1-17	18
144688001	M - 1-18	18
144689101	M - 1-19	18
145446001	M - 1-11	18
	Z - 12-1	20
145472001	E - 1	6
145478001	E - 28	6
145480001	E - 25	6
145573000	Z - 17	20
145619001	L - 81	16
146036101	Z - 19-2	22
146037001	Z - 19-3	22
146038001	Z - 19-7	22
146039001	Z - 18-1	20
146141001	B - 8	2
146253000	L - 85	16
146293001	Z - 19-8	22
146354001	C - 12	4
146367001	Z - 19-4	22
146536001	L - 100	16
146598001	A - 5	2
147513001	E - 8-1	6
147846002	E - 4	6
148005001	H - 12	10
148394000	L - 26	14
148491001	F - 8	8
148492101	F - 4	8
148494001	F - 1	8
148502000	J - 2	12
148503000	J - 1	12
148762001	L - 34	14
148821001	J - 10-3	12
	J - 12	12
148890109	Z - 23	22
149566009	M - 1-14	18
150106003	Z - 14-4	20
150172003	Z - 14-3	20
150174000	Z - 14-5	20
150179002	Z - 14-7-1	20
150180001	Z - 14-8	20
150182000	Z - 14-9	20
150188009	Z - 14-11-1	20
150191002	Z - 14-2-2	20
150206002	Z - 14-2-1	20
150553003	M - 3	18
150556001	E - 15	6
150988001	L - 9	14
151027001	H - 22-1-1	10
151029001	H - 22-2-2	10
151030001	H - 22-2-3	10
151145001	H - 22-2-1	10
151146001	H - 22-2-1	10
151602002	A - 17	2
151927001	L - 32	14
152973001	L - 61	14
152974001	L - 58	14

CODE	REF.NO.	PAGE
152973001	L - 61	14
152974001	L - 58	14
	L - 65	14
153920001	L - 64	14
154702001	Z - 11	20
155491001	M - 1-2	18
156070002	L - 68	16
156112003	Z - 14-1	20
158115001	B - 18	2
	J - 11-1	12
158769001	M - 1-9	18
159359201	C - 1	4
159360101	C - 1-5	4
159436001	H - 31	10
159805001	M - 1-12	18
180157001	B - 14	2
180733001	D - 7	4
181427001	Z - 18	20
181486001	J - 9	12
181919101	E - 8	6
183480009	Z - 30	22

brother

ブラザー工業株式会社

〒467 名古屋市瑞穂区河岸一丁目1番1号
TEL (052) 824-2392(代)

BROTHER INDUSTRIES, LTD. NAGOYA, JAPAN

118-841
195841-101
1991, 02

Printed in Japan/Gedruckt in Japan/Imprimé au Japon/Impreso en Japón

From the library of: Superior Sewing Machine & Supply LLC